

ANALISIS LINGKUNGAN KESELAMATAN KERJA / JOB SAFETY ENVIRONMENT ANALYSIS

Pekerjaan / Task	DA DIFFERENTIAL LFJ	Nomor JSEA / JSEA Number	01	Halaman / Page	1	Dari / Of	2
------------------	---------------------	--------------------------	----	----------------	---	-----------	---

Tanggal Pembuatan JSEA / Date of JSEA	30 Desember 2025	Departemen / Dept	SERVICE	Tempat Kerja / Work Location	WORKSHOP TAB
---------------------------------------	------------------	-------------------	---------	------------------------------	--------------

Disusun Oleh / Compiled By	ZAYED	TTD / Sign		Review Oleh / Reviewed By		TTD / Sign		Atasan Superior		TTD / Sign	
----------------------------	-------	------------	--	---------------------------	--	------------	--	-----------------	--	------------	--

Apakah Anda sudah terlatih untuk melakukan pekerjaan ini? / Are you properly trained to complete these task? Ya / Yes Tidak / No

Apakah Anda memerlukan untuk memastikan bahwa pekerjaan selesai tanpa adanya kecelakaan kerja? / What do you need to ensure this job is completed incident free?

Tools yang digunakan sudah sesuai dengan Manual

Siapa yang bertanggung jawab untuk menghentikan pekerjaan jika terjadi perubahan pekerjaan atau gangguan kondisi lingkungan kerja? / Who is responsible for Stop Work Authority if change job or workplace distraction could?

ABCD-1 (Technician Leader) / Mr. X (Customer)

Apakah Anda memerlukan peralatan LOTO? / Are you need LOTO Equipments? Ya / Yes Tidak / No

Apakah Anda mengetahui ERP/MERP dari pekerjaan yang sedang dilakukan? Ya / Yes Tidak / No *Jika tidak, silahkan tambahkan dalam urutan langkah tugas diawal*

Kondisi Lingkungan / Environmental Conditions	Cuaca / Weather	MENDUNG	Medan / Terrain	DATA
---	-----------------	---------	-----------------	------

Pengendalian Sumber Bahaya / Hazardous Energy Control	<input type="checkbox"/> Listrik / Electrical	<input checked="" type="checkbox"/> Gravitasi (Benda jatuh, tertimpa) / Gravitation (Falling objects, struck down)	<input type="checkbox"/> Pneumatik / Pneumatic
	<input type="checkbox"/> Hidraulik / Hydraulic	<input checked="" type="checkbox"/> Mekanis / Mechanical	<input type="checkbox"/> Panas / Thermal

APD yang diperlukan / Required PPE	<input checked="" type="checkbox"/> Helm / Safety Helm	<input type="checkbox"/> Pelindung Muka / Face shield	<input checked="" type="checkbox"/> Kacamata / Safety Glass
	<input checked="" type="checkbox"/> Sarung Tangan / Hand Gloves	<input type="checkbox"/> Pelindung Pernafasan / Respiratory Protection	<input type="checkbox"/> Perlindungan Kejatuhan / Fall Protection
	<input checked="" type="checkbox"/> Sepatu / Safety Shoes	<input type="checkbox"/> Pelindung Telinga / Hearing Protection	<input type="checkbox"/> Lain-Lain / Other

Hal yang perlu dipertimbangkan dalam mengidentifikasi bahaya / These to consider in identify hazards :

1 Bahaya Keselamatan : Kondisi tidak aman yang dapat menyebabkan injury atau kematian seperti terpeleceh, terpeleset/terjatuh, tertimpa dll.
Safety Hazard : unsafe conditions that can cause injury or even death, such as spill/falls, pinch point, struck by, etc.

2 Bahaya Fisik : Listrik, Api/ledakan, Kebisingan, Radiasi, Panas, Tekanan, Terjepit, Tersandung/Terjatuh, Tertimpa, Getaran.
Physical Hazards : Electrical, Fire/Explosion, Noise, Radiations, Thermal, Pressure, Pinch Point, Slips/Falls, Struck by, Vibration.

3 Bahaya Kimia : Terhirup, terkena kulit, injeksi, tertelan, terserap.
Chemical Hazards : Inhalation, skin contact, injection, ingestion, absorption.

4 Bahaya Biologi : Patogen yang ditularkan melalui darah, jamur, tanaman/serangga/hewan.
Biological Hazards : bloodborne pathogens, mold, Plant/Insect/Animals

5 Bahaya Ergonomi : Gerakan berulang-ulang, beban yang berlebihan, Postur Janggal, Durasi kerja, Desain area kerja.
Ergonomic Hazards : Repetitions, Forcefull extention, Awkward Posture, Duration, Work area desain.

6 Bahaya Organisasi : stres atau bahaya terkait dengan masalah tempat kerja yang menyebabkan efek jangka panjang atau pendek, beban kerja yang berat dan kekerasan ditempat kerja.
Organizational hazards: stressors or hazards associated with workplace issues that cause long or short term effects heavy workloads, stressful interactions and workplaces violence.

No	Urutan Dasar Langkah Tugas / Job Steps (* Maksimum 15 Langkah / Maximum 15 Steps)	Bahaya Yang Terkait / Potential Hazard(s)	Tindakan Perbaikan / Recommended Action
1.	Walk around Inspection	1.1 Kaki tersandung komponen	1.1.1 Berhati-hati saat inpeksi 1.1.2 Gunakan safety shoes
		1.2 Tangan tergores sudut tajam	1.2.1 Gunakan safety gloves
2.	Prepare tools	2.1 Kepala terbentur Pegangan tool box	2.1.1 Perhatikan area sekitar tool box 2.1.2 Tetap Fokus saat bekerja 2.1.3 Gunakan Safety helmet
		2.2 Tangan tergores sudut tajam toolbox	2.2.1 Hindari tempat pemegangan yang salah 2.2.2 Gunakan Safety gloves
		2.3 Kaki tertimpa tool	2.3.1 Jangan bergurau saat membawa tools 2.3.2 Gunakan safety shoes
3.	Doing Disassembly Differential	3.1 Terjatuh saat Membuka bolt	3.1.1 Posisikan badan dengan benar 3.1.2 Gunakan APD lengkap
		3.2 Kepala terbentur hook crane	3.2.1 Saling berkomunikasi 3.2.2 Memakai Safety helmet
		3.3 Jari terjepit Slings	3.3.1 Hindari titik jepit 3.3.2 Berkomunikasi dengan 1 tim 3.3.3 Gunakan APD lengkap
		3.4 Tertimpa komponen differential	3.4.1 Terapkan 10 langkah lifting dengan benar

Sling

SWL = 150 kg

75 kg

Webbing

80°

SHACKLE

SWL = 4,5 Ton

~~Prosedur Pengangkatan~~

Prosedur Jacking Pada Forklift

1. Putar battery disconnect switch ke posisi OFF
2. Aktifkan parking brake. Ganjal ban belakang ✓
3. Pilih peralatan yang tepat ✓
4. Posisikan hydraulic jack di bagian . Casis belakang ✓
5. Pompa hydraulic jack sampai mengangkat bagian belakang forklift sampai ketinggian yang dibutuhkan untuk memasukkan wheel stand pada roda forklift ✓
6. Masukkan wheel stand & sejajarkan posisinya dengan roda forklift ✓
7. Turunkan perlahan hydraulic jack sampai roda tertahan dengan kuat pada wheel stand ✓
8. Posisikan hydraulic jack di bagian casing depan ✓
9. Pompa hydraulic jack sampai mengangkat bagian depan forklift sampai ketinggian yg dibutuhkan untuk memasukkan wheel stand pada roda forklift
10. Masukkan wheel stand & sejajarkan posisinya dengan roda forklift ✓
11. Turunkan perlahan hydraulic jack sampai roda tertahan dgn kuat pada wheel stand ✓
12. Tarik keluar hydraulic jack dari bagian bawah forklift ✓

SMCS - 3256, 3258

!10016954

Assembly Procedure

Table 1

Required Tools			
Tool	Part Number	Part Description	Qty
A	1U-7502	Repair Stand	1
B	439-3938	Link Bracket As	2
C	456-4371	Lever Hoist	1
D	1P-5546	Crossblock	1
H	6V-4070	Spanner Wrench	1
L	-	Grease	-
M	9S-8864	Plate	1
	5P-8715	Forcing Bolt	1
N	350-7768	Electric Hydraulic Pump Gp ((115 V)	1
	350-7769	Electric Hydraulic Pump Gp (230 V)	1
	478-3993	Torque Wrench	1
P	9U-5017	Torque Wrench	1
	8T-5096	Tool Group	1

NOTICE

Keep all parts clean from contaminants.

Contaminants may cause rapid wear and shortened component life.

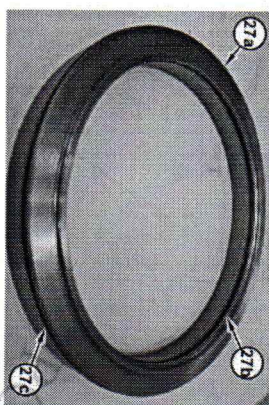

Illustration 1

g03868985

1. Install D-ring seal (27b) and D-ring seal (27c) in clutch piston (27a). Apply a liberal amount of grease to D-ring seal (27b) and D-ring seal (27c).

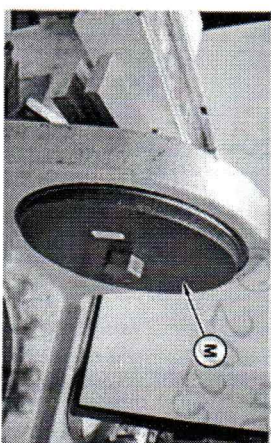

Illustration 2

g03868988

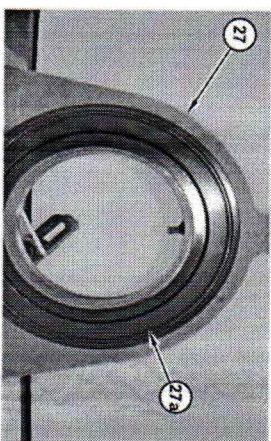

Illustration 3

g03866237

2. Use Tooling (M) to install clutch piston (27a) into carrier assembly (27).

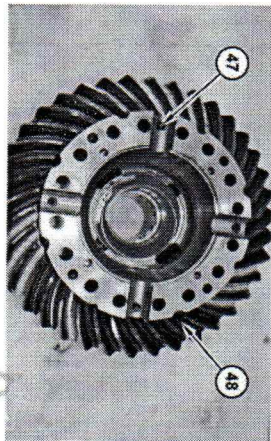

Illustration 4

g03866231

3. Install roll pins (47) into bevel gear (48).

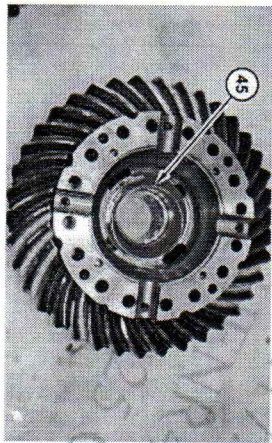

Illustration 5

g03866175

4. Install thrust washer (45).

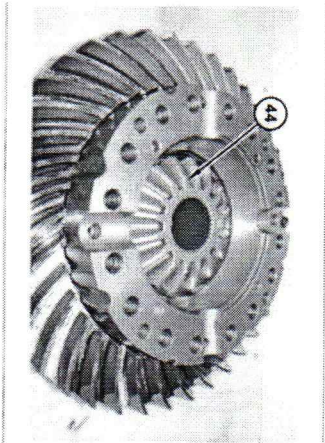

Illustration 6

g03866169

5. Lubricate gear (44) with the lubricant that is being sealed. Install gear (44). Make sure that gear (44) turns freely.

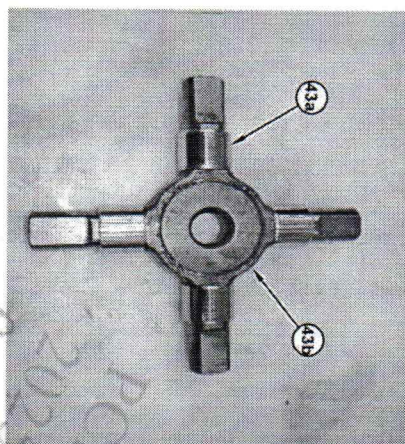

Illustration 7

g03870010

6. Lubricate spider (43b) with the lubricant that is being sealed. Lubricate bearing (43a) with the lubricant that is being sealed. Install bearing sleeves (43a) on spi

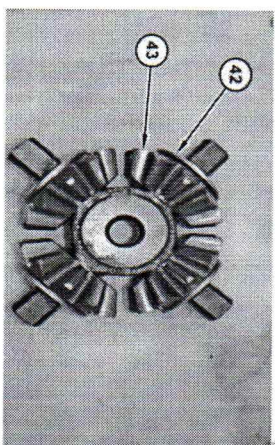

Illustration 8

g03866131

7. Lubricate gears (43) and thrust washers (42) with the lubricant that is being sealed. Make sure gears (43) and thrust washers (42) turn freely.

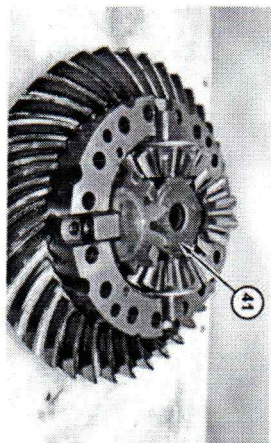

Illustration 9

g03866124

8. Install spider gear assembly (41).

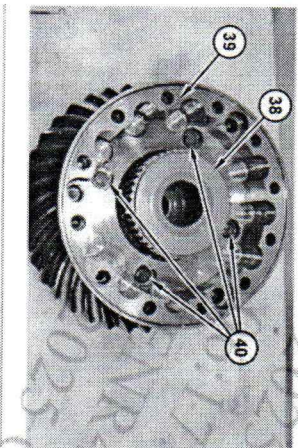

Illustration 10

g03866119

Note: Align the housing to the orientation as marked during the disassembly.

9. Align and install housing (39). Lubricate gear (38) with the lubricant that is being sealed. Install gear (38) and bolts (40). Make sure that gear (38) turns freely.

10. Perform the following procedure to control preload accurately and backlash setting:

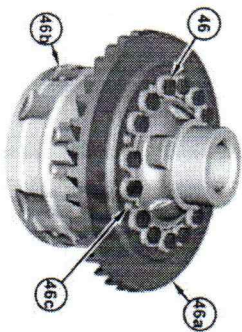

Illustration 11

g03870565

Note: Do not install all bolts (46) until the following procedure is complete.

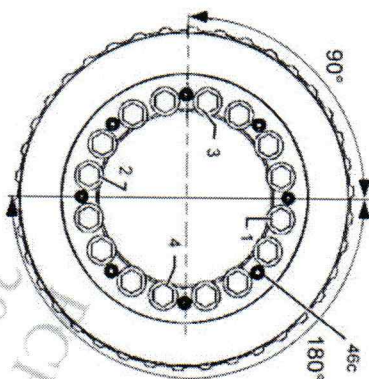

Illustration 12

g03870679

- Raise bevel gear (46a) to a temperature between 70° C (158° F) and 120° C (248° F). Install bevel gear (46a) to differential case (46b).
- Install spring pins (46c) to align bevel gear (46a) to differential case (46b).
- Install four bolts (46) as indicated by callouts (1) through (4) in Illustration 12. Tighten bevel gear (46a) to differential case (46b), tighten four bolts (46) in the pattern indicated by callouts (1) through (4). Tighten four bolts (46) to a minimum torque of 70 N·m (52 lb ft).
- Install remaining bolts (46) loosely (a minimum of one to two revolutions).
- Confirm bevel gear (46a) is seated in differential case (46b).
- Allow bevel gear (46a) to cool to a temperature of 30° C (86° F) or less.
- Loosen four initially tightened bolts (46) as indicated in Illustration 12.
- Tighten bolts (46) to a final torque of 95 ± 10 N·m (70 ± 7 lb ft). Turn bolts (46) an additional 180 degrees ± 10 degrees.

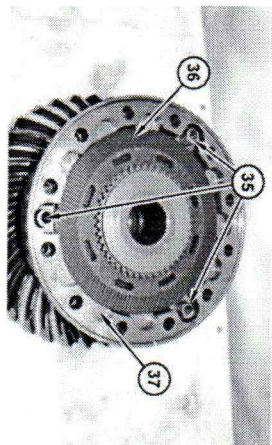

Illustration 13

g03866114

⚠ WARNING

Improper assembly of parts that are spring loaded can cause bodily injury.

To prevent possible injury, follow the established assembly procedure and wear protective equipment.

11. Thoroughly coat eight separator plates (37) and eight friction discs (36) with the lubricant that is being sealed.
12. First install bottom separator plate (37), then install one friction disc (36). Continue in this way until you install the last friction disc (36) at the top.
13. Install springs (35).

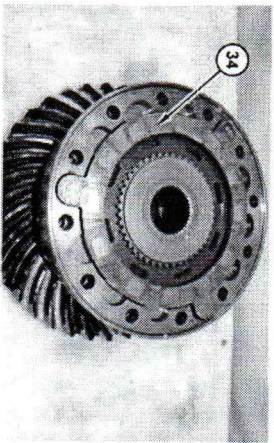

Illustration 14

g03866103

14. Install thrust plate (34).

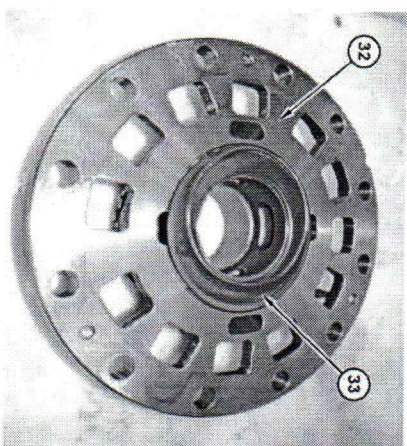

Illustration 15

g06637152

15. Lubricate thrust washer (33) with the lubricant that is being sealed. Install thrust on back side of top clutch housing (32).

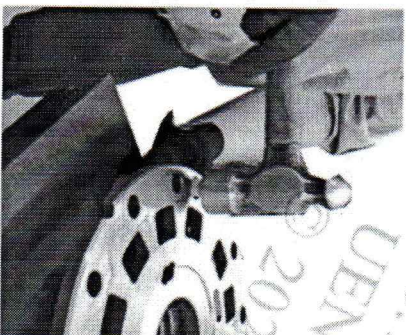

Illustration 16

g06783402

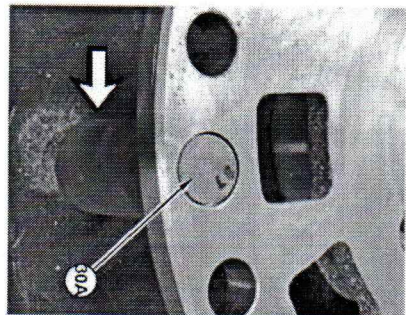

Illustration 17

g06783403

16. Lower the temperature of dowels (30A). Use a suitable hammer to install dowels (30A). Support the housing when installing the dowels.

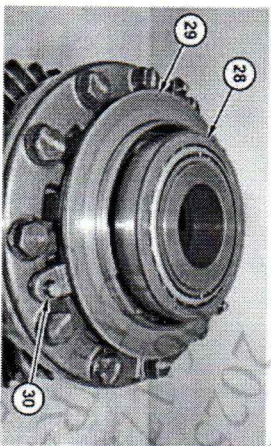

Illustration 18

g06789571

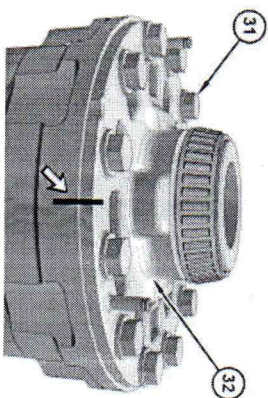

Illustration 19

g06637164

17. Install thrust ring (29).

18. Install O-ring seals (30) and bearing cup (28).

Note: Align the housing to the orientation as marked during the disassembly.

19. Align and install top clutch housing (32).

20. Install bolts (31). Tighten bolts (31) to a torque of 270 ± 40 N·m (200 ± 30 lb ft).



Illustration 20

g03866235

21. Install bearing race (26a). Install bearing (26b) on to carrier assembly (27).

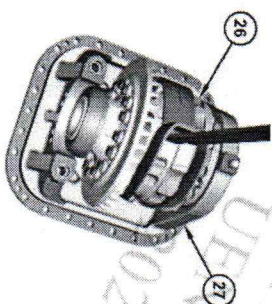

Illustration 21

g03866038

22. Use a suitable lifting device to install differential assembly and bevel gear (26) in assembly (27). The weight of differential assembly and bevel gear (26) is approximately 115 kg (254 lb).

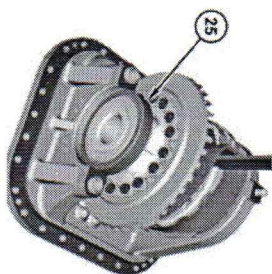

Illustration 22

g03866037

23. Install bearing cup (25).

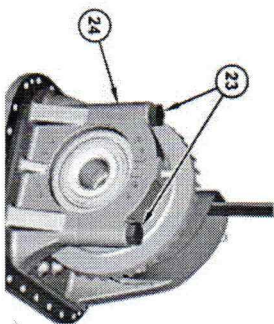

Illustration 23

g03866014

24. Install bearing cap (24). Tighten bolts (23) to a torque of 70 N·m (50 lb ft).

Note: This torque is the initial torque for bolts (23).

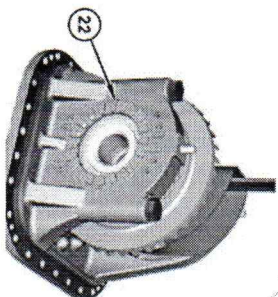

Illustration 24

g03866009

25. Install adjusting ring (22). Repeat for the opposite side. Ensure that adjusting ring freely.

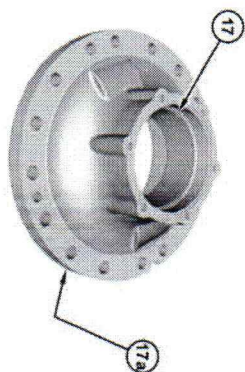

Illustration 25

g03865975

26. Install bearing cup (17) and bearing cup (17a).

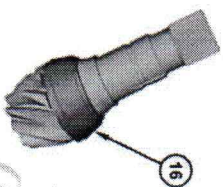

Illustration 26

g03865974

27. Raise the temperature of bearing cone (16). Install bearing cone (16) on pinion shaft.

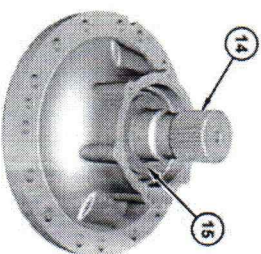

Illustration 27

g03865972

28. Install bearing cone (15). Install pinion shaft (14).
29. Perform the following Steps for setting backlash:

a. Secure the pinion housing in a suitable holding fixture.

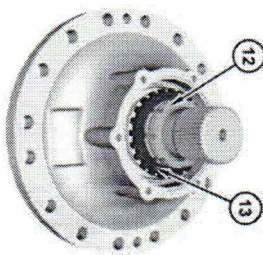

Illustration 28

g03865906

- b. Install notched washer (13) and locknut (12). Tighten locknut (12) until you attain a rolling torque of 0.67 to 1.35 N·m (6 to 12 lb in).

Note: Rotation of the pinion is critical to achieve a proper seating of all the components.

- c. Rotate the pinion several times to ensure that the bearings are fully seated.

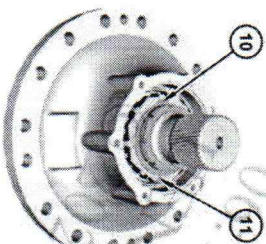

Illustration 29

g03865905

- d. Install locking washer (11) so the tabs line up with the notches on the notched washer. Locking washer (11) has eight different positions to align the tabs with the notches in the notched washer. If locking washer (11) does not fully align with the notched washer, position locking washer (11) so that locking washer (11) is very close to fitting into the

notches of the notched washer. Tighten the locknut until locking washer (11) notches of the notched washer.

- e. Measure the rolling torque again to confirm that the rolling torque is still 0.67 to 1.35 N·m (6 to 12 lb in).

f. If the rolling torque is still 0.67 to 1.35 N·m (6 to 12 lb in), then install retaining lip seal (9) into the groove of the locknut that is closer to the locking washer. Make sure retaining ring (10) is fully seated in the groove.

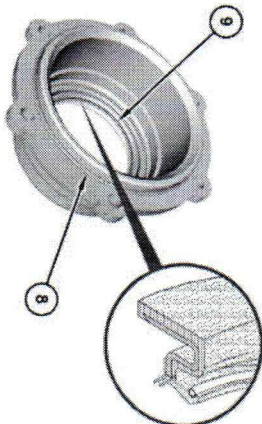

Illustration 30

g06550667

30. Install lip seal (9) with the spring facing up. Lubricate lip seal (9) with the lubricant being sealed. Install O-ring seal (8).

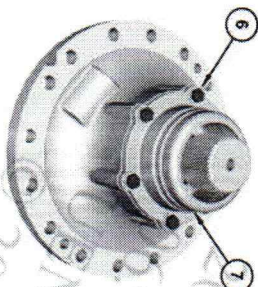

Illustration 31

g03865553

31. Install retainer (7) and bolts (6).

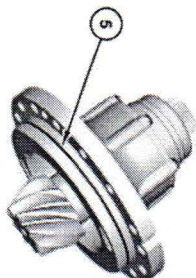

Illustration 32

g03865544

32. Install O-ring seal (5).

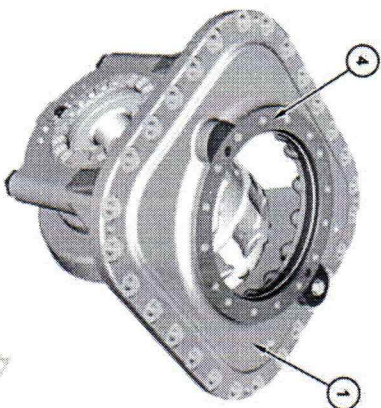

Illustration 33

g03867030

33. Rotate and reposition differential and bevel gear assembly (1) by 90 degrees.

Note: Use the original shims (4) or provide new shims (4) that are the same thickness as the original shims that were removed.

Note: If original shims (4) are not available, then install 80 percent of the new shim pack. In this case, you will be required to adjust the thickness of shims (4) after you determine the tooth contact pattern.

34. Install shims (4) in the differential and bevel gear assembly (1).

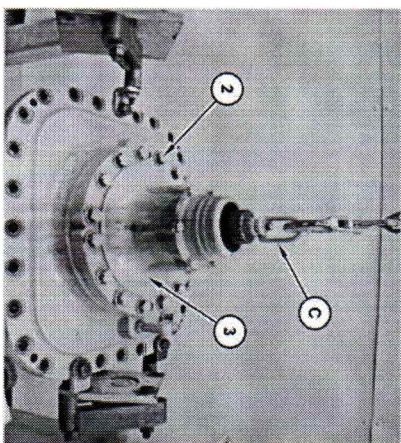

Illustration 34

g03865468

35. Attach suitable Tooling (C) and a suitable lifting device to the yoke. The weight of housing (3) is approximately 75 kg (165 lb).

36. Install pinion housing (3) and bolts (2). Tighten bolts (2) to a torque of 270 ± 40 N (199 ± 30 lb ft).

37. Perform the following procedure to set bearing end play and to set backlash of the gear.

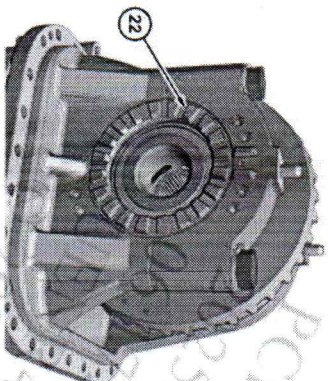

Illustration 35

g06588820

a. The bearing cups have adjusting rings (22). Adjusting rings (22) are used for bearing end play and for setting the back lash of the bevel gear.

Illustration 43

g03869469

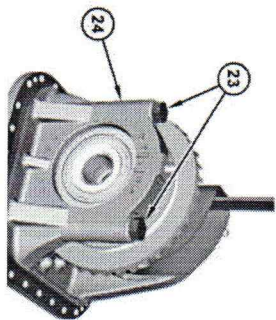

Illustration 44

g03866014

38. Use Tooling (N) to tighten bolts (23) to a torque of 1800 ± 200 N·m (1328 ± 148 lb ft).

Note: After final torque of bolts (23), re-check the gear backlash. Final torque may reduce backlash and take the backlash out of spec.

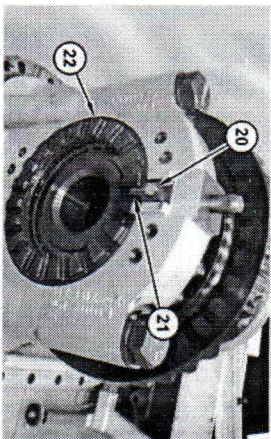

Illustration 45

g03870871

39. Install lock (21) and bolt (20) that secure locking ring (22). Repeat for the other side.

40. The rolling torque for the complete system should not exceed 4 N·m (35 lb in).

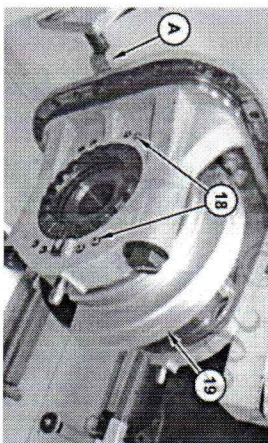

Illustration 46

g03865976

Illustration used for bolt locations.



Illustration 47

g07615705

41. Rotate the carrier and differential assembly by 90 degrees on Tooling (A).

42. Install guard (19) and four bolts (18) as shown in Illustration 47.

End By:

a. Install the front or rear differential and bevel gear. Refer to Differential and Bevel Gear (Front and Rear) - Remove and Install.

PCP-00022950

2025/12/30

06:16:59+07:00

j06238129

© 2025 Caterpillar Inc.

PCP-00022950
 2025/12/30
 06:17:07+07
 UENP

PCP-00022950

Caterpillar Inc.
 1227
 06:17:00

SMCS - 3256, 3258

I10135287

Disassembly Procedure

Table 1

Required Tools			
Tool	Part Number	Part Description	Qty
A	1U-7502	Repair Stand	1
B	439-3938	Link Bracket As	2
C	456-4371	Lever Hoist	1
D	1P-5546	Crossblock	1
E	6V-3160	Double Acting Cylinder	1
F	1P-0520	Driver Group	1
H	6V-4070	Spanner Wrench	1
J	8B-7551	Bearing Puller	1
K	5F-7343	Bearing Puller Gp	1

Start By:

- a. Remove the front or rear differential assembly. Refer to Differential and Bevel Gear (Front and Rear) - Remove and Install.

NOTICE

Keep all parts clean from contaminants.

Contaminants may cause rapid wear and shortened component life.

1. Apply location marks on all housings and case assemblies for assembly purposes.

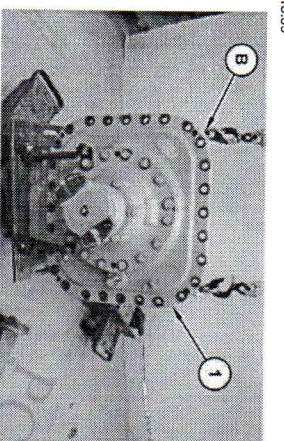

Illustration 1

g03865438

2. Attach Tooling (B) and a suitable lifting device to differential and bevel gear assembly (1) is approximately 322 kg (710 lbs).

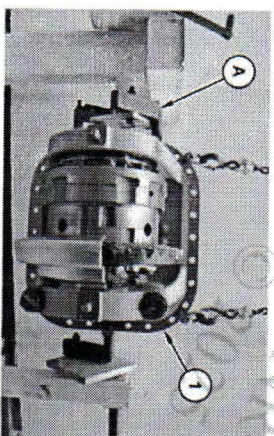

Illustration 2

g03865440

3. Position and place differential and bevel gear assembly (1) onto Tooling (A). Refer to Tooling (B) and the suitable lifting device.

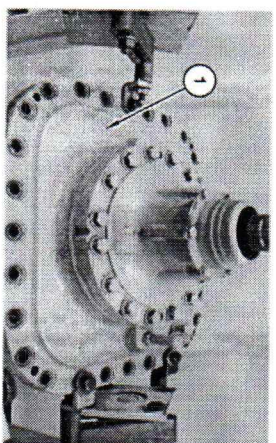

Illustration 3

g03865449

4. Rotate differential and bevel gear assembly (1) by 90 degrees.

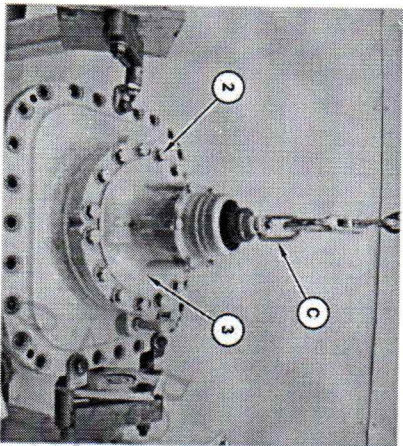

Illustration 4

g03865468

5. Attach Tooling (C) and a suitable lifting device to the yoke. The weight of pinion housing (3) is approximately 75 kg (165 lb). Remove bolts (2).

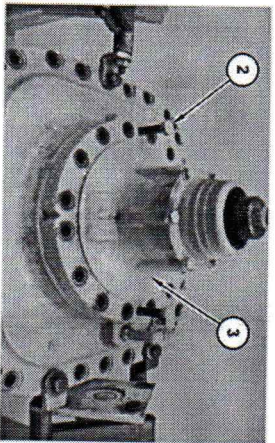

Illustration 5

g03865471

6. Install two bolts (2) in the threaded holes of pinion housing (forcing bolt holes). Tighten two bolts (2) evenly to separate pinion housing (3). Remove pinion housing (3).

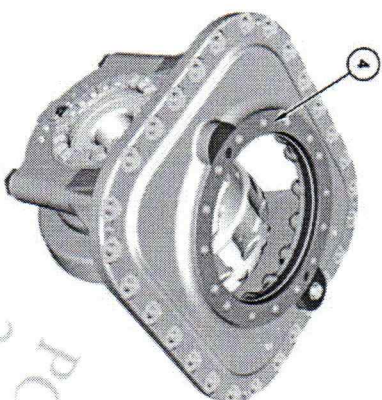

Illustration 6

g03865526

7. Remove shims (4).

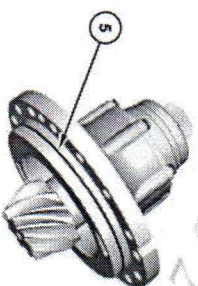
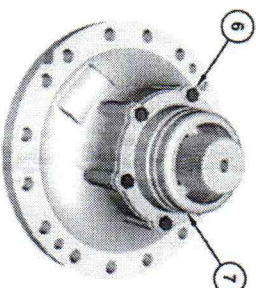

Illustration 7

g03865544

8. Remove O-ring seal (5).



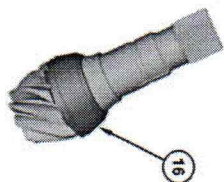

Illustration 14

g03865974

Typical Example

16. Use a suitable press and Tooling (J) (not shown) to remove bearing cup (16).

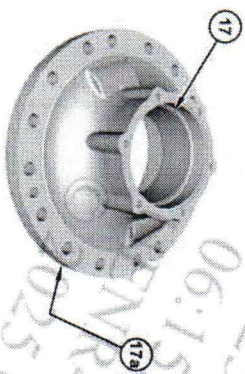

Illustration 15

g03865975

17. Remove bearing cup (17) and bearing cup (17a).

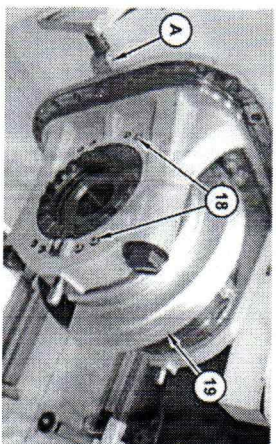

Illustration 16

g03865976

18. Rotate the carrier and differential assembly by 90 degrees on Tooling (A).
19. Remove four bolts (18) and guard (19).

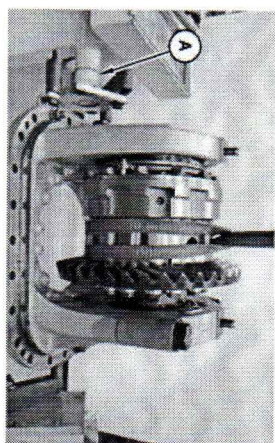

Illustration 17

g03865999

20. Use a suitable lifting device to position the carrier and differential assembly on T. The weight of the carrier and differential assembly is approximately 234 kg (516

21. Rotate the carrier and differential assembly an additional 90 degrees on Tooling

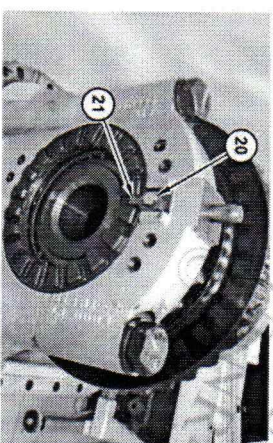

Illustration 18

g03866003

22. Remove bolt (20) and lock (21). Repeat for the opposite side.

Demonstrate Carrying Out Jacking, Blocking and Lifting of Heavy Equipment and Components Safely

Skill Number CO-OP15GN108

Full Name: Zayed Syaid A.

SN/SAP ID: _____

Job Title: VA Differential LFJ

Branch/Area: _____

PERFORMANCE TASK:

Given a large machine component, the necessary lifting equipment and lifting chains/slings, the student is to lift and move the component from one location to another. The component is to be correctly supported once placed on the ground or workbench. The component is to be supported in a manner that will enable service work to be carried out.

The student must be able to:

- Selecting tools used and identify SWL correctly
- Jack and block Heavy Equipment correctly and safely
- Lift and support engine or machine component correctly
- Follow service procedure on Service Manual correctly
- Follow standard safety & contamination control procedure related to the job
- Perform communication & etiquette manner

Students are to be given a copy of TQL005 Practical Activity 2 – Student Performance sheet and fill out appropriate areas. It is recommended that Facilitators put questions to students regarding the findings of their inspections and subsequent report. The student will also be required to complete relevant workplace documentation and is to observe the correct safety procedures at all times

Safety and Contamination Control must be applied to this process at all times.

Prerequisite	Yes	No	N/A	Hints
The Student must complete the knowledge assessment. Minimum passing grade 80%.	✓			Score jacking, blocking, and lifting course or subject.

Tasks	Completed			Observation
	Yes	No	N/A	
Preparation Prepare related literature Work instructions are used to determine job requirements, including method, process and equipment Job specifications are read and interpreted. Information is accessed from manufacturer/ component supplier specifications and correctly incorporated. Information is accessed from manufacturer/ component supplier specifications and correctly incorporated	✓			Practical Activity 1
Prepare required equipment	✓			Observe if candidate to and observing Me specifications and intervals
Prepare related tools Materials, components, equipment and tooling are identified and checked for safe and effective operation	✓			Refer to MOD res Material, compone and equipment to work are identified, s prepared in accorda procedures
Prepare Safety & Contamination Control equipment	✓			

Tasks	Completed			Observation /
	Yes	No	N/A	
Perform etiquette/manner when starting the job	✓			
Meet the customer / assessor	✓			
Perform etiquette/manner when opening the interaction.	✓			• Perform smile & gr • Introduce Student
Explain the purpose of Student's activity.	✓			
Ask permission to perform the job.	✓			

Demonstrate Carrying Out Jacking, Blocking and Lifting of Heavy Equipment and Components Safely

Skill Number CO-OP15GN108

Full Name: Zayed Syowiq A.

SNSAP ID: _____

Job Title: DA Differential LFJ

Branch/Area: _____

PERFORMANCE TASK:

Given a large machine component, the necessary lifting equipment and lifting chains/slings, the student is to lift and move the component from one location to another. The component is to be correctly supported once placed on the ground or workbench. The component is to be supported in a manner that will enable service work to be carried out.

The student must be able to:

- Selecting tools used and identify SWL correctly
- Jack and block Heavy Equipment correctly and safely
- Lift and support engine or machine component correctly
- Follow service procedure on Service Manual correctly
- Perform standard safety & contamination control procedure related to the job
- Perform communication & etiquette manner

Students are to be given a copy of TCOL005 Practical Activity 2 – Student Performance sheet and fill out appropriate areas. It is recommended that Facilitators put questions to students regarding the findings of their inspections and subsequent report. The student will also be required to complete relevant workplace documentation and is to observe the correct safety procedures at all times
Safety and Contamination Control must be applied to this process at all times.

Prerequisite	Yes	No	N/A	Hints
The Student must complete the knowledge assessment. Minimum passing grade 80%.	✓			

Tasks	Completed			Observation /
	Yes	No	N/A	
Preparation Prepare related literature Work instructions are used to determine job requirements, including method, process and equipment Job specifications are read and interpreted. Information is accessed from manufacturer/ component supplier specifications and correctly incorporated. Information is accessed from manufacturer/ component supplier specifications and correctly incorporated.	✓			
Prepare required equipment	✓			
Prepare related tools Materials, components, equipment and tooling are identified and checked for safe and effective operation	✓			
Prepare Safety & Contamination Control equipment	✓			

Tasks	Completed			Observation /
	Yes	No	N/A	
Perform etiquette/manner when starting the job	✓			
Meet the customer / assessor	✓			
Perform etiquette/manner when opening the interaction.	✓			
Explain the purpose of Student's activity.	✓			
Ask permission to perform the job.	✓			

Demonstrate Carrying Out Jacking, Blocking and Lifting of Heavy Equipment and Components Safely

Skill Number CO-OP15GN108

Full Name: Zayed Syawiq A. SN/SAP ID: _____
 Job Title: DA Diffrential L F J Branch/Area: _____

PERFORMANCE TASK:

Given a large machine component, the necessary lifting equipment and lifting chains/slings, the student is to lift and move the component from one location to another. The component is to be correctly supported once placed on the ground or workbench. The component is to be supported in a manner that will enable service work to be carried out.

The student must be able to:

- Selecting tools used and identify SWL correctly
- Jack and block Heavy Equipment correctly and safely
- Lift and support engine or machine component correctly
- Follow service procedure on Service Manual correctly
- Follow standard safety & contamination control procedure related to the job
- Perform communication & etiquette manner

Students are to be given a copy of T.CLO05 Practical Activity 2 – Student Performance sheet and fill out appropriate areas. It is recommended that Facilitators put questions to students regarding the findings of their inspections and subsequent report. The student will also be required to complete relevant workplace documentation and is to observe the correct safety procedures at all times

Safety and Contamination Control must be applied to this process at all times.

Prerequisite	Yes	No	N/A	Hints
The Student must complete the knowledge assessment. Minimum passing grade 80%.	✓			



Tasks	Completed			Observation /
	Yes	No	N/A	
Preparation				
Prepare related literature				
Work instructions are used to determine job requirements, including method, process and equipment				
Job specifications are read and interpreted. Information is accessed from manufacturer/component supplier specifications and correctly incorporated.	✓			
Information is accessed from manufacturer/component supplier specifications and correctly incorporated				
Prepare required equipment	✓			
Prepare related tools				
Materials, components, equipment and tooling are identified and checked for safe and effective operation	✓			
Prepare Safety & Contamination Control equipment	✓			

Tasks	Completed			Observation /
	Yes	No	N/A	
Perform etiquette/manner when starting the job				
Meet the customer / assessor	✓			
Perform etiquette/manner when opening the interaction.	✓			
Explain the purpose of Student's activity.	✓			
Ask permission to perform the job.	✓			



Tasks	Completed			Observation / Hints
	Yes	No	N/A	
Visual Check	✓			
Pre-inspection procedures	✓			
Crane/Lifting apparatus inspection	✓			
Lifting equipment	✓			
Support materials	✓			

Tasks	Completed			Observation / Hints
	Yes	No	N/A	
Visual Check	✓			
Site location selected	✓			
Supports in place	✓			
Jacking and Blocking	✓			
Jacking procedures	✓			
Jack conducted	✓			
Blocking procedure	✓			
Blocking conducted	✓			
Blocking allows for service work to be conducted	✓			
Lifting	✓			
Hook up procedures	✓			
Lift conducted	✓			
Load moved to chosen site	✓			
Load lowered and supported	✓			
Support allows for service work to be conducted	✓			

Tasks	Completed			Observation / Hints
	Yes	No	N/A	
Use of Tools and Equipment	✓			
Tests and adjustments carried out according to manufacturer's specifications and procedures	✓			
Service is completed without damage to equipment and tools	✓			
Equipment and tooling is cleaned and returned to its correct location	✓			
Work area left clean and tidy	✓			

Tasks	Completed			Observation / Hints
	Yes	No	N/A	
Reporting	✓			
All relevant documentation completed correctly, and approved by customer (if required).	✓			

Tasks	Completed			Observation / Hints
	Yes	No	N/A	
Safety	✓			
Using PPE related to the job	✓			
Follows relevant Workplace Safety Guidelines (LOTO, Safety Equipment)	✓			
State and follow Safety Precautions	✓			
Student completes job without accident due to incorrect procedure using hand tools.	✓			
Tasks completed without damage equipment and tools	✓			

Tasks	Completed		Observation / Hints
	Yes	No	
Contamination Control	✓		
Environmental Practices & Housekeeping	✓		

Tasks	Completed			Observation / Hints
	Yes	No	N/A	
Perform etiquette/manner after completing the job	✓			
Perform etiquette/manner when closing the communication.	✓			

General Comments

RESULT: **COMPETENT** **NOT YET COMPETENT** (please

Serviceman: Zayed Syawiq A. 8 / 1 / 2026

Assessor: Setiawan Tuhu B. 8 / 1 / 2026

Supervisor: _____ Date _____ Signature _____

Data Recorded: _____ Name _____ Date _____ Signature _____