

Demonstrate Selecting, Using and Maintaining a range of Precision and Non-Precision Tools to Accurately Measure

Skill Number CO-OP15GN105

Full Name: Hameza Fathurrahman

No ID: _____

Validation Date: 21/11/2016

School: SMKN 1 Singasari

PERFORMANCE TASK:

Given some measuring tools, the student is requested to perform the following tasks on various measuring tools:

- Selecting
- Using
- Recording
- Maintaining

The student will be instructed to measure with a non-precision gauge such as: steel ruler, feeler gauge and precision tools such as vernier callipers, outside, inside and depth micrometer the dimension of some given parts. Literature and measuring tools will be made available but will not be provided directly to the student.

The student must be able to perform the following task:

- Demonstrate using various measuring tools on an engine or other system components.

Safety and Contamination Control must be always applied to this process.

Prerequisite	Yes	No	N/A	Hints
The student must complete the knowledge assessment. Minimum passing grade 80%.	✓			Score measuring tools Course or subject.

Tasks	Completed			Observation / Hints
	Yes	No	N/A	
Preparation	✓			
Prepare related literature	✓			
Prepare required equipment	✓			
Prepare related tools	✓			
Prepare Safety & Contamination Control equipment	✓			

Tasks	Completed			Observation / Hints
	Yes	No	N/A	
Perform etiquette/manner when starting the job				
Meet the customer / assessor	✓			
Perform etiquette/manner when opening the interaction.	✓			<ul style="list-style-type: none"> • Perform smile & greetings. • Introduce Student's identity
Explain the purpose of Student's activity.	✓			
Ask permission to perform the job.	✓			

Tasks	Completed			Observation / Hints
	Yes	No	N/A	
Selecting, Using and Maintaining a range of Precision and Non-Precision Tools				
1. Inspect the measuring tool before using	✓			Visual inspection of the measuring tool for wear, cracks, damage
2. Clean tool and component	✓			Using of consumables CC tools
3. Calibrate measuring tools before using	✓			Tools should be calibrated as given procedure
4. Measure component use measuring tools with tolerance allowance 0.5 mm (0.02" or 1/25") for non-precision measuring tools and 0.025 mm (0.001") for precision measuring tools.	✓			Thread identification gauge and tire pressure gauge without tolerance
5. Tasks completed without damage to equipment and tools	✓			Component and tooling are cleaned and assembled as given procedure
6. Equipment and tooling are cleaned and returned to its correct location	✓			Cleaned and stored equipment/tools on the right place.
7. Record the reading of the measurements	✓			Write the actual reading on the paper given by the assessor
Documentation:				
Take picture if needed				



Tasks	Completed			Observation / Hints
	Yes	No	N/A	
Perform close the job by ensuring all systems or conditions is in the standard condition	<input checked="" type="checkbox"/>	<input type="checkbox"/>	<input type="checkbox"/>	<ul style="list-style-type: none"> Find the improper condition. Communicate the finding to the customer/assessor.
Ensure all systems or conditions are in standard condition.	<input checked="" type="checkbox"/>	<input type="checkbox"/>	<input type="checkbox"/>	

Tasks	Completed			Observation / Hints
	Yes	No	N/A	
Reporting All relevant documentation completed correctly and approved by customer (if required).	<input checked="" type="checkbox"/>	<input type="checkbox"/>	<input type="checkbox"/>	<ul style="list-style-type: none"> Completing the Task List Completing Measurement Form/Related Check Sheet, if required Create Service Report (SIMS), if required Create SPR, if required Documenting the failed or damaged parts, if required Provide Technical Analysis Report/Failure Analysis Report, if required.
	<input type="checkbox"/>	<input type="checkbox"/>	<input type="checkbox"/>	

Tasks	Completed			Observation / Hints
	Yes	No	N/A	
Safety Using PPE related to the job	<input checked="" type="checkbox"/>	<input type="checkbox"/>	<input type="checkbox"/>	
Follows relevant Workplace Safety Guidelines (LOTO, Safety Equipment)	<input checked="" type="checkbox"/>	<input type="checkbox"/>	<input type="checkbox"/>	Comply with safety regulation that applied on the workplace
State and follow Safety Precautions	<input checked="" type="checkbox"/>	<input type="checkbox"/>	<input type="checkbox"/>	<ul style="list-style-type: none"> Create Job Safety Analysis Student must follow safety procedure refer to service manual or SIS related to job
Service man completes job without accident due to incorrect procedure using hand tools.	<input checked="" type="checkbox"/>	<input type="checkbox"/>	<input type="checkbox"/>	<ul style="list-style-type: none"> Correct working position Correct hand tool related to the job
Tasks completed without damage equipment and tools	<input checked="" type="checkbox"/>	<input type="checkbox"/>	<input type="checkbox"/>	

Tasks	Completed			Observation / Hints
	Yes	No	N/A	
Contamination Control	<input checked="" type="checkbox"/>	<input type="checkbox"/>	<input type="checkbox"/>	
Environmental Practices & Housekeeping	<input checked="" type="checkbox"/>	<input type="checkbox"/>	<input type="checkbox"/>	<ol style="list-style-type: none"> Waste is minimized, waste material, including sludge, solids and other wastes are sorted and stored in bins for recycling or disposal Packaging of goods received is sorted and reused or disposed of by recycling Materials that can be reused are cleaned and stored Waste and scrap are removed following workplace procedures All fluids are disposed of in accordance with enterprise policies and procedures

Tasks	Completed			Observation / Hints
	Yes	No	N/A	
Perform etiquette/manner after completing the job	<input checked="" type="checkbox"/>	<input type="checkbox"/>	<input type="checkbox"/>	
Perform etiquette/manner when closing the communication.	<input checked="" type="checkbox"/>	<input type="checkbox"/>	<input type="checkbox"/>	<ul style="list-style-type: none"> Perform smile & greetings. Ask permission to leave or end the interaction.



General Comments

Three horizontal lines for general comments.

RESULT: **COMPETENT** **NOT YET COMPETENT** (please check (X))

Student: Karnah Cahurrahman 21/11/2026 [Signature]

Assessor: [Signature] 21/11/2026 [Signature]

Supervisor: _____ [Signature]

Data Recorded: _____ [Signature]

Demonstrate Selecting, Using and Maintaining a range of Precision and Non-Precision Tools to Accurately Measure

Skill Number CO-OP15GN105

Full Name: Honzal, Fortunado

No ID: _____

Validation Date: 31/1/2026

School: SJKTN 1 Singasari

PERFORMANCE TASK:

Given some measuring tools, the student is requested to perform the following tasks on various measuring tools:

- Selecting
- Using
- Recording
- Maintaining

The student will be instructed to measure with a non-precision gauge such as: steel ruler, feeler gauge and precision tools such as vernier calipers, outside, inside and depth micrometer, the dimension of some given parts. Literature and measuring tools will be made available but will not be provided directly to the student.

The student must be able to perform the following task:

- Demonstrate using various measuring tools on an engine or other system components.

Safety and Contamination Control must be always applied to this process.

Prerequisite	Yes	No	N/A	Hints
The student must complete the knowledge assessment. Minimum passing grade 80%.	✓			

Tasks	Completed			Observation / Hints
	Yes	No	N/A	
Preparation				
Prepare related literature	✓			
Prepare required equipment	✓			
Prepare related tools	✓			
Prepare Safety & Contamination Control equipment	✓			

Tasks	Completed			Observation / Hints
	Yes	No	N/A	
Perform etiquette/manner when starting the job	✓			
Meet the customer / assessor	✓			
Perform etiquette/manner when opening the interaction.	✓			
Explain the purpose of Student's activity.	✓			
Ask permission to perform the job.	✓			

Tasks	Completed			Observation / Hints
	Yes	No	N/A	
Selecting, Using and Maintaining a range of Precision and Non-Precision Tools				
1. Inspect the measuring tool before using	✓			
2. Clean tool and component	✓			
3. Calibrate measuring tools before using	✓			
4. Measure component use measuring tools with tolerance allowance 0.5 mm (0.02" or 1/25") for non-precision measuring tools and 0.025 mm (0.001") for precision measuring tools.	✓			
5. Tasks completed without damage to equipment and tools	✓			
6. Equipment and tooling are cleaned and returned to its correct location	✓			
7. Record the reading of the measurements	✓			
Documentation:				
Take picture if needed				

Tasks	Completed			Observation / Hints
	Yes	No	N/A	
Perform close the job by ensuring all systems or conditions is in the standard condition	✓			
Ensure all systems or conditions are in standard condition.	✓			

Tasks	Completed			Observation / Hints
	Yes	No	N/A	
Reporting				
All relevant documentation completed correctly and approved by customer (if required).	✓			

Tasks	Completed			Observation / Hints
	Yes	No	N/A	
Safety				
Using PPE related to the job	✓			
Follows relevant Workplace Safety Guidelines (LOTO, Safety Equipment)	✓			
State and follow Safety Precautions	✓			
Service man completes job without accident due to incorrect procedure using hand tools.	✓			
Tasks completed without damage equipment and tools	✓			

Tasks	Completed			Observation / Hints
	Yes	No	N/A	
Contamination Control				
Environmental Practices & Housekeeping	✓			

Tasks	Completed			Observation / Hints
	Yes	No	N/A	
Perform etiquette/manner after completing the job				
Perform etiquette/manner when closing the communication.	✓			

General Comments

RESULT: **COMPETENT** **NOT YET COMPETENT** (please check (✓))

Student: Hannah Fokuramon Date: 31/1/2026 Signature: [Signature]

Assessor: Selviaeva TB Date: 31/1/2026 Signature: [Signature]

Supervisor: _____ Date: _____ Signature: _____

Data Recorded: _____ Date: _____ Signature: _____

ANALISIS LINGKUNGAN KESELAMATAN KERJA / JOB SAFETY ENVIRONMENT ANALYSIS

Pekerjaan Task	Measure socket shaft CG.4	Nomor JSEA JSEA Number	Halaman Page	Dari Of
-------------------	---------------------------	---------------------------	-----------------	------------

Tanggal Pembuatan JSEA Date of JSEA	29 Januari 2016	Departemen Dept	Service	Tempat Kerja Work Location	Workshop TAB
--	-----------------	--------------------	---------	-------------------------------	--------------

Disusun Oleh Compiled By	Hamezan	TTD Sign	<i>[Signature]</i>	Review Oleh Reviewed By		TTD Sign		Atasan Superior		TTD Sign	
-----------------------------	---------	-------------	--------------------	----------------------------	--	-------------	--	--------------------	--	-------------	--

Apakah Anda sudah terlatih untuk melakukan pekerjaan ini ? / Are you properly trained to complete these task ? Ya / Yes Tidak / No

Apa yang Anda perlukan untuk memastikan bahwa pekerjaan selesai tanpa adanya kecelakaan kerja ? / What do you need to ensure this job is completed incident free ?

Tools yang digunakan sudah sesuai dengan Manual

Siapa yang bertanggung jawab untuk menghentikan pekerjaan jika terjadi perubahan pekerjaan atau gangguan kondisi lingkungan kerja ? / Who is responsible for Stop Work Authority if change job or workplace distraction could ?

ABCD-1 (Technician Leader) / Mr. X (Customer)

Apakah Anda memerlukan peralatan LOTO ? / Are you need LOTO Equipments ? Ya / Yes Tidak / No

Apakah Anda mengetahui ERP/MERP dari pekerjaan yang sedang dilakukan ? Ya / Yes Tidak / No *Jika tidak, silahkan tambahkan dalam urutan langkah tugas diawal*

Kondisi Lingkungan / Environmental Conditions	Normal	Cuaca / Weather	Cerah	Medan / Terrain	Rata
---	--------	-----------------	-------	-----------------	------

Pengendalian Sumber Bahaya / Hazardous Energy Control	<input type="checkbox"/> Listrik / Electrical	<input checked="" type="checkbox"/> Gravitasi (Benda jatuh, tertimpa) / Gravitation (Falling objects, struck down)	<input type="checkbox"/> Pneumatik / Pneumatic
	<input type="checkbox"/> Hidraulik / Hydraulic	<input type="checkbox"/> Mekanis / Mechanical	<input type="checkbox"/> Panas / Thermal

APD yang diperlukan / Required PPE	<input checked="" type="checkbox"/> Helm / Safety Helm	<input type="checkbox"/> Pelindung Muka / Face shield	<input checked="" type="checkbox"/> Kacamata / Safety Glass
	<input checked="" type="checkbox"/> Sarung Tangan / Hand Gloves	<input type="checkbox"/> Pelindung Pemasfasan / Respiratory Protection	<input type="checkbox"/> Perlindungan Kejutuhan / Fall Protection
	<input checked="" type="checkbox"/> Sepatu / Safety Shoes	<input type="checkbox"/> Pelindung Telinga / Hearing Protection	<input type="checkbox"/> Lain-Lain / Other

Hal yang perlu dipertimbangkan dalam mengidentifikasi bahaya / These to consider in identify hazards :

- 1 **Bahaya Keselamatan** : Kondisi tidak aman yang dapat menyebabkan injury atau kemalitan seperti terjepit, terpeleset/terjatuh, tertimpa dll.
Safety Hazard : unsafe conditions that can cause injury or even death, such as spill/falls, pinch point, struck by, etc.
- 2 **Bahaya Fisik** : Listrik, Apliedakan, Kebisingan, Radiasi, Panas, Tekanan, Terjepit, Tersandung/Terjatuh, Tertimpa, Getaran.
Physical Hazards : Electrical, Fire/Explosion, Noise, Radiations, Thermal, Pressure, Pinch Point, Slips/Falls, Struck by, Vibration.
- 3 **Bahaya Kimia** : Terhirup, terkena kulit, injeksi, tertelan, terserap.
Chemical Hazards : Inhalation, skin contact, injection, ingestion, absorption.
- 4 **Bahaya Biologi** : Patogen yang ditularkan melalui darah, jamur, tanaman/serangga/hewan.
Biological Hazards : bloodbone pathogens, mold, Plant/Insect/Animals
- 5 **Bahaya Ergonomi** : Gerakan berulang-ulang, beban yang berlebihan, Postur Janggal, Durasi kerja, Desain area kerja.
Ergonomic Hazards : Repetitions, Forcefull extention, Awkward Posture, Duration , Work area desain.
- 6 **Bahaya Organisasi** : stres atau bahaya terkait dengan masalah tempat kerja yang menyebabkan efek jangka panjang atau pendek, beban kerja yang berat dan kekerasan ditempat kerja.
Organizational hazards : stressors or hazards associated with workplace issues that cause long or short term effects heavy workloads, stressful interactions and workplaces violence.

No	Urutan Dasar Langkah Tugas / Job Steps (* Maksimum 15 Langkah / Maximum 15 Steps)	Bahaya Yang Terkait / Potential Hazard(s)	Tindakan Perbaikan / Recommended Action
1.	Prepare APD	1.1 Posisi tidak ergonomi	1.1.1 nyamankan posisi 1.2.2 Lakukan sesuai prosedur
2.	walk around inspection	2.1 tempat romai 2.2 Tempat komponen berantakan	2.1.1 memasang safety line 2.2.1 Diratakan dan dikembalikan ke rak
3	prepare tools & komponen	3.1 Tertimpa komponen 3.2. Terjepit komponen 3.3 komponen terjatuh	3.1.1 Bawa komponen sesuai prosedur 3.2.1 hindari titik jepit 3.3.1 perhatikan kontak fisik
4	Cleaning component	4.1 Mata terkenca kvd 90 4.2 Iritasi karena cairan pembersih	4.1.1 gunakan safety glasses 4.2.1 gunakan safety gloves karet
5	measure component	5.1 tools kotor	5.1.1 Lap dengan white towel
6.	House keeping	6.1 Tersandung komponen	6.1.1 Perhatikan lingkungan sekitar 6.1.2 gunakan safety shoes.

SMCS - 1102

i02966721

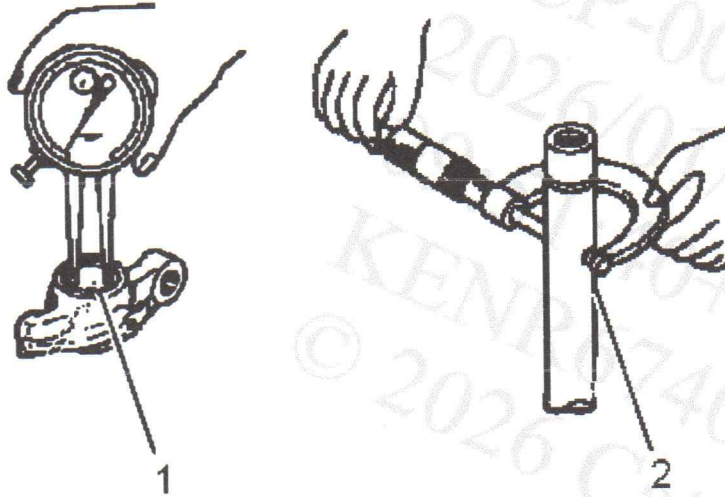

Illustration 1

g01411580

- (1) Bore in rocker arm bushing for shaft ... 24.949 to 24.975 mm (0.9822 to 0.9833 inch)
- (2) Diameter of rocker arm shaft ... 24.915 to 24.928 mm (0.9809 to 0.9814 inch)

Clearance of rocker arm bushing and shaft

Minimum ... 0.021 mm (0.0008 inch)

Maximum ... 0.060 mm (0.0024 inch)

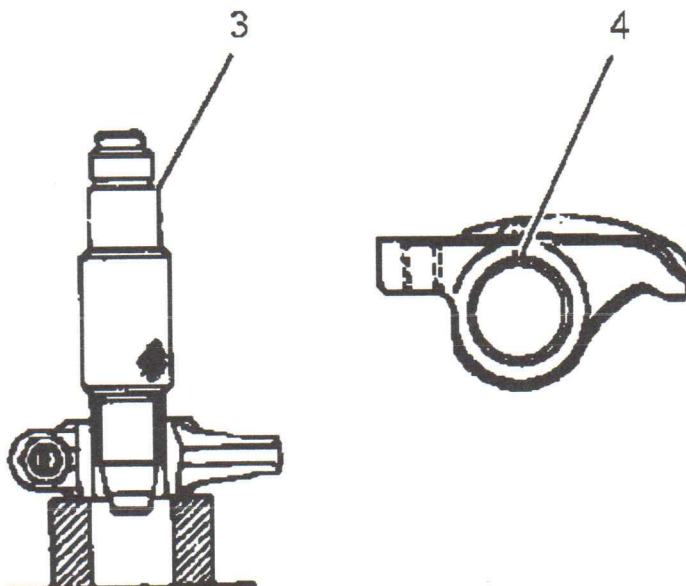

Subject: English

Page No.:

