

**Demonstrate Selecting, Using and Maintaining Various Special Tools Correctly**

Skill Number CO-OP15GN104

Full Name: Rahmat Zaini Baraka

No ID: \_\_\_\_\_

Validation Date: 20 12 25

School: SMK11 1 SGS

**PERFORMANCE TASK:**

Given some special tools, the student is requested to perform the following tasks:

- Selecting, using, maintaining various Special Tools in the installation of Engine or other system components.
- Perform close the job by ensuring all systems or conditions is in the standard condition.

Safety and Contamination Control must be applied to this process. All literatures will be available.

Prerequisite	Yes	No	N/A	Hints
The student must complete the knowledge assessment. Minimum passing grade 80%.				

Tasks	Completed			Observation / Hints
	Yes	No	N/A	
Preparation				
Prepare related literature				
Prepare required equipment				
Prepare related tools				
Prepare Safety & Contamination Control equipment				

Tasks	Completed			Observation / Hints
	Yes	No	N/A	
Perform etiquette/manner when starting the job				
Meet the customer / assessor				
Perform etiquette/manner when opening the interaction.				
Explain the purpose of Student's activity.				
Ask permission to perform the job.				

Tasks	Completed			Observation / Hints
	Yes	No	N/A	
<b>Selecting, Using and Maintaining Various Special Tools</b>				
1. Inspect the Special Tool before using				
2. Calibrate the special tool before using				
3. Remove and install or disassemble and assemble conducted according to correct procedures				
4. Tasks completed without damage to equipment and tools				
5. Equipment and tooling is cleaned and returned to its correct location				
6. Work area left clean and tidy				
<b>Documentation:</b>				
Take picture if needed				

Tasks	Completed			Observation / Hints
	Yes	No	N/A	
<b>Perform close the job by ensuring all systems or conditions is in the standard condition</b>				
Ensure all systems or conditions are in standard condition.				



Tasks	Completed			Observation / Hints
	Yes	No	N/A	
Reporting All relevant documentation completed correctly and approved by customer (if required).				

Tasks	Complete		Observation / Hints
	Yes	No	
Safety			
Using APD related to the job			
Follows relevant workplace safety guidelines (tag out, safety equipment)			
State and follow safety precautions			
Service man completes job without accident due to incorrect procedure using hand tools.			
Tasks completed without damage equipment and tools			

Tasks	Complete		Observation / Hints
	Yes	No	
Contamination Control			
Environmental Practices & Housekeeping			

Tasks	Completed			Observation / Hints
	Yes	No	N/A	
Perform etiquette/manner after completing the job				
Perform etiquette/manner when closing the communication.				

General Comments

Blank area for general comments.

RESULT:  COMPETENT  NOT YET COMPETENT  (please check (N))

Student: Rahmat Zamri Date: 29/12/25 Signature: [Signature]

Assessor: Selvicson TB Date: 29/12/25 Signature: [Signature]

Supervisor: \_\_\_\_\_ Date: \_\_\_\_\_ Signature: \_\_\_\_\_

Data Recorded: Name: \_\_\_\_\_ Date: \_\_\_\_\_ Signature: \_\_\_\_\_



**Demonstrate Selecting, Using and Maintaining Various Special Tools Correctly**

Skill Number CO-OP15GN104

Full Name: Rahmat Zamri Bardo No ID: \_\_\_\_\_  
 Validation Date: 29 12 2025 School: SUKN 1 SGS

**PERFORMANCE TASK:**

Given some special tools, the student is requested to perform the following tasks:

- Selecting, using, maintaining various Special Tools in the installation of Engine or other system components.
- Perform close the job by ensuring all systems or conditions is in the standard condition.

Safety and Contamination Control must be applied to this process. All literatures will be available.

Prerequisite	Yes	No	N/A	Hints
The student must complete the knowledge assessment. Minimum passing grade 80%.	<input checked="" type="checkbox"/>			Score special tools Course or subject.

Tasks	Completed			Observation / Hints
	Yes	No	N/A	
Prepare related literature	<input checked="" type="checkbox"/>			
Prepare required equipment	<input checked="" type="checkbox"/>			
Prepare related tools	<input checked="" type="checkbox"/>			
Prepare Safety & Contamination Control equipment	<input checked="" type="checkbox"/>			

Tasks	Completed			Observation / Hints
	Yes	No	N/A	
Perform etiquette/manner when starting the job	<input checked="" type="checkbox"/>			
Meet the customer / assessor	<input checked="" type="checkbox"/>			
Perform etiquette/manner when opening the interaction.	<input checked="" type="checkbox"/>			<ul style="list-style-type: none"> <li>• Perform smile &amp; greetings.</li> <li>• Introduce Student's identity</li> </ul>
Explain the purpose of Student's activity.	<input checked="" type="checkbox"/>			
Ask permission to perform the job.	<input checked="" type="checkbox"/>			

Tasks	Completed			Observation / Hints
	Yes	No	N/A	
<b>Selecting, Using and Maintaining Various Special Tools</b>				
1. Inspect the Special Tool before using	<input checked="" type="checkbox"/>			Visual inspection of the Special Tool for wear, cracks, damage
2. Calibrate the special tool before using	<input checked="" type="checkbox"/>			<ul style="list-style-type: none"> <li>• Torque wrench</li> </ul>
3. Remove and install or disassemble and assemble conducted according to correct procedures	<input checked="" type="checkbox"/>			Equipment and tooling are identified and checked for safe and effective operation and must refer to Service manual or SIS
4. Tasks completed without damage to equipment and tools	<input checked="" type="checkbox"/>			Component and tooling are cleaned and stored on the right place
5. Equipment and tooling is cleaned and returned to its correct location	<input checked="" type="checkbox"/>			Cleaned and stored equipment tools on the right place.
6. Work area left clean and tidy	<input checked="" type="checkbox"/>			Area cleaned from spills and wastes.
<b>Documentation:</b>				
Take picture if needed				

Tasks	Completed			Observation / Hints
	Yes	No	N/A	
Perform close the job by ensuring all systems or conditions is in the standard condition	<input checked="" type="checkbox"/>			
Ensure all systems or conditions are in standard condition.	<input checked="" type="checkbox"/>			<ul style="list-style-type: none"> <li>• Find the improper condition.</li> <li>• Communicate the finding to the customer/assessor.</li> </ul>



Tasks	Completed		Observation / Hints
	Yes	No	
Reporting All relevant documentation completed correctly and approved by customer (if required).	✓		<ul style="list-style-type: none"> <li>• Completing the Task List</li> <li>• Completing Measurement Form/Related Check Sheet, if required</li> <li>• Create Service Report (SIMS), if required</li> <li>• Create SPR, if required</li> <li>• Documenting the failed or damaged parts, if required</li> <li>• Provide Technical Analysis Report/Failure Analysis Report, if required.</li> </ul>

Tasks	Complete		Observation / Hints
	Yes	No	
Safety Using APD related to the job	✓		
Follows relevant workplace safety guidelines (tag out, safety equipment)	✓		<ul style="list-style-type: none"> <li>• Comply with safety regulation that applied on the workplace</li> </ul>
State and follow safety precautions	✓		<ul style="list-style-type: none"> <li>• Create Job Safety Analysis</li> <li>• Student must follow safety procedure refer to service manual or SIS related to job</li> </ul>
Service man completes job without accident due to incorrect procedure using hand tools.	✓		<ul style="list-style-type: none"> <li>• Correct working position.</li> <li>• Correct hand tool related to the job</li> </ul>
Tasks completed without damage equipment and tools	✓		

Tasks	Complete		Observation / Hints
	Yes	No	
Contamination Control Environmental Practices & Housekeeping	✓		<ol style="list-style-type: none"> <li>1. Waste is minimized, waste material, including sludge, solids and other wastes are sorted and stored in bins for recycling or disposal</li> <li>2. Packaging of goods received is sorted and reused or disposed of by recycling</li> <li>3. Materials that can be reused are cleaned and stored</li> <li>4. Waste and scrap are removed following workplace procedures</li> <li>5. All fluids are disposed of in accordance with enterprise policies and procedures</li> </ol>

Tasks	Completed		Observation / Hints
	Yes	No	
Perform etiquette/manner after completing the job Perform etiquette/manner when closing the communication.	✓		<ul style="list-style-type: none"> <li>• Perform smile &amp; greetings.</li> <li>• Ask permission to leave or end the interaction.</li> </ul>



General Comments

pelajari cih fungsi & definiti  
dan special tools.

RESULT:

COMPETENT

NOT YET COMPETENT

(please check (X))

Student:

Rahmat Lanza Bardo F

Name

Date

29.12.2025

Assessor:

Rhaswan TB 29-12-2025

Name

Date

Signature

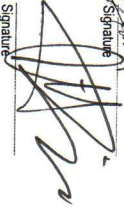

Supervisor:

Name

Date

Signature

Data Recorded:

Name

Date

Signature



**ANALISIS LINGKUNGAN KESELAMATAN KERJA / JOB SAFETY ENVIRONMENT ANALYSIS**

Pekerjaan / Task	DM 250 Engine 3306	Nomor JSEA / JSEA Number		Halaman / Page	1	Dari / Of	2
------------------	--------------------	--------------------------	--	----------------	---	-----------	---

Tanggal Pembuatan JSEA / Date of JSEA	29 12 2025	Departemen / Dept	TAB	Tempat Kerja / Work Location	
---------------------------------------	------------	-------------------	-----	------------------------------	--

Disusun Oleh / Compiled By	Bardo	TTD Sign		Review Oleh / Reviewed By	SHE	TTD Sign		Atasan / Superior		TTD Sign	
----------------------------	-------	----------	--	---------------------------	-----	----------	--	-------------------	--	----------	--

Apakah Anda sudah terlatih untuk melakukan pekerjaan ini ? / Are you properly trained to complete these task ?  Ya / Yes  Tidak / No

Apa yang Anda perlukan untuk memastikan bahwa pekerjaan selesai tanpa adanya kecelakaan kerja ? / What do you need to ensure this job is completed incident free ?

Tools yang digunakan sudah sesuai dengan Manual

Sapa yang bertanggung jawab untuk menghentikan pekerjaan jika terjadi perubahan pekerjaan atau gangguan kondisi lingkungan kerja ? / Who is responsible for Stop Work Authority if change job or workplace distraction could ?

ABCD-1 (Technician Leader) / Mr. X (Customer)

Apakah Anda memerlukan peralatan LOTO ? / Are you need LOTO Equipments ?  Ya / Yes  Tidak / No

Apakah Anda mengetahui ERP/MERP dari pekerjaan yang sedang dilakukan ?  Ya / Yes  Tidak / No *Jika tidak, silahkan tambahkan dalam urutan langkah tugas diawal*

Kondisi Lingkungan / Environmental Conditions	Cuaca / Weather	Lerah	Medan / Terrain	Rata
---	-----------------	-------	-----------------	------

Pengendalian Sumber Bahaya / Hazardous Energy Control	<input checked="" type="checkbox"/> Listrik / Electrical	<input checked="" type="checkbox"/> Gravitasi (Benda jatuh, tertimpa) / Gravitation (Falling objects, struck down)	<input type="checkbox"/> Pneumatik / Pneumatic
	<input type="checkbox"/> Hidraulik / Hydraulic	<input checked="" type="checkbox"/> Mekanis / Mechanical	<input checked="" type="checkbox"/> Panas / Thermal

APD yang diperlukan / Required PPE	<input checked="" type="checkbox"/> Helm / Safety Helm	<input type="checkbox"/> Pelindung Muka / Face shield	<input checked="" type="checkbox"/> Kacamata / Safety Glass
	<input checked="" type="checkbox"/> Sarung Tangan / Hand Gloves	<input type="checkbox"/> Pelindung Pernafasan / Respiratory Protection	<input type="checkbox"/> Perlindungan Kejatuhan / Fall Protection
	<input checked="" type="checkbox"/> Sepatu / Safety Shoes	<input type="checkbox"/> Pelindung Telinga / Hearing Protection	<input type="checkbox"/> Lain-Lain / Other .....

Hal yang perlu dipertimbangkan dalam mengidentifikasi bahaya / These to consider in identify hazards :

**1 Bahaya Keselamatan :** Kondisi tidak aman yang dapat menyebabkan injury atau kematian seperti terpelesep, terpelesep/terjatuh, tertimpa dll.  
Safety Hazard : unsafe conditions that can cause injury or even death, such as spill/falls, pinch point, struck by, etc.

**2 Bahaya Fisik :** Listrik, Api/ledakan, Kebisingan, Radiasi, Panas, Tekanan, Terjepit, Tersandung/Terjatuh, Tertimpa, Getaran.  
Physical Hazards : Electrical, Fire/Explosion, Noise, Radiations, Thermal, Pressure, Pinch Point, Slips/Falls, Struck by, Vibration.

**3 Bahaya Kimia :** Terhirup, terkena kulit, injeksi, tertelan, terserap.  
Chemical Hazards : Inhalation, skin contact, injection, ingestion, absorption.

**4 Bahaya Biologi :** Patogen yang ditularkan melalui darah, jamur, tanaman/serangga/hewan.  
Biological Hazards : bloodborne pathogens, mold, Plant/Insect/Animals

**5 Bahaya Ergonomi :** Gerakan berulang-ulang, beban yang berlebihan, Postur Janggal, Durasi kerja, Desain area kerja.  
Ergonomic Hazards : Repetitions, Forcefull extention, Awkward Posture, Duration , Work area desain.

**6 Bahaya Organisasi :** stres atau bahaya terkait dengan masalah tempat kerja yang menyebabkan efek jangka panjang atau pendek, beban kerja yang berat dan kekerasan ditempat kerja.  
Organizational hazards : stressors or hazards associated with workplace issues that cause long or short term effects heavy workloads, stressful interactions and workplaces violence.

No	Urutan Dasar Langkah Tugas / Job Steps (* Maksimum 15 Langkah / Maximum 15 Steps)	Bahaya Yang Terkait / Potential Hazard(s)	Tindakan Perbaikan / Recommended Action
<b>A</b>	<b>ERP/MERP</b>		
	1. Saat pekerjaan terjadi gempa	tertimpa reruntuhan	1.1 Segera evakuasi menuju master point baru ditetapkan/ tempat terbuka 1.2 Melaporkan kejadian kepada atasan
	2. Saat pekerjaan ada teknisi yang pingsan	Cidera kepala, tangan tergores	2.1 Lakukan protokol P3K 2.2 Segera evakuasi korban menuju fasilitas kesehatan terdekat 2.3 Melaporkan kejadian kepada atasan
<b>B</b>	<b>Langkah Pekerjaan</b>		
1	Prepare APD	Tersandung Meja Ergonomi saat memanggng sepatu	1.1 Pindahkan Benda yg menghalangi 1.2 Fokus saat Prepare 1.3 Posisikan badan yang nyaman
2	Walk Around Inspection	Terpelesep Fluida kaki tersandung engine	2.1 Bersihkan dgn Majun 2.2 berhati hati saat melangkah
3	Prepare Tools	terjepit laci toolbox tersandung komponen Terjepit Roda tool box	3.1 hindari titik jepit 3.2 Berhati hati saat bekerja 3.3 Pindahkan benda yg menghalangi 3.4 hindari titik jepit Roda 3.5 Dorong tool box saat memindah
4	Dong Pre Maintenance	Terjepit komponen Terpelesep Fluida berceceran Ter-bentur komponen engine	4.1 Hati hati saat bekerja 4.2 hati hati saat bekerja 4.3 Bersihkan Fluida dgn Majun 4.4 Jauhkan posisi badan dari benda tajam

**ANALISIS LINGKUNGAN KESELAMATAN KERJA / JOB SAFETY ENVIRONMENT ANALYSIS**

Pekerjaan  
Task

PM 250 Engine 3306

Nomor JSEA  
SEA Number

Halaman  
Page

2

Dari  
Of

2

Nomor Formulir  
Form Number

SHE.SHE.FRM.005.R03

No Urutan Dasar Langkah Tugas / Job Steps

Bahaya Yang Terkait / Potential Hazard(s)

Tindakan Perbaikan / Recommended Action

5 House kaca PMG

Terserang listrik  
Debu masuk pernafasan  
Terdapat penerangan

4.5 Fokus saat bekerja  
4.6. Pindah kabel ke tempat yang aman  
5.1. Pakai Masker  
5.2. Berhenti sejenak dengan mesin

Bukti sosialisasi / Evidence of socialization :

No	Nama / Name	TTD / Sign
1	Friski	
2	Ega	
3	Saka Alzena	
4		
5		

No	Nama / Name	TTD / Sign

No	Nama / Name	TTD / Sign

Bagian Dari / Part Of

SHE.SHE.SOP.003.R04



PT Trakindo Utama

SERVICE PARTS REQUISITION

WORK ORDER NO.	A/C NO.	CUSTOMER			MODEL 9NR	SERIAL NO. 3306 B	
SEGMENT NO.	WARRANTY	<input type="checkbox"/>	UNIT DOWN	<input checked="" type="checkbox"/>	SCHEDULED	<input type="checkbox"/>	
						CATERPILLAR PARTS	
						YES	NO
CUSTOMER REPRESENTATIF NAME			CUSTOMER REPRESENTATION SIGNATURE			INITIAL SUPPLY PSD REF NO.	
DELIVER TO	DATE TIME OF DELIVERY	PREPARED BY			TOTAL PARTS ESTIMATE		
APPROVED BY Bardo		DATE TIME APPROVED 20/12/25					

ITEM	PART NUMBER	CHANGED TO	DESCRIPTION	QTY		APPROVAL	UNIT PRICE	EXTENDED PRICE	R E C D	
				EST	ACT					
1	1R-0720		Oil Filter	1	1					
2	36-9844		engine bit	1	1					
3	335-9830		engine oil	2	2					
4	914-2341		element hydraulic	1	1					
5										
6										
7										
8										
9										
10										
11										
12										
13										
14										
15										
16										
17										
18										
19										
20										
21										
22										
23										
24										
25							TOTAL C/F			

\* APPROVAL CODE:

- C - CUSTOMER REQUEST
- I - FOUND BY INSPECTOR
- R - FOUND DURING REPAIR

- O - APPROVED BY CUSTOMER
- X - NOT APPROVED BY CUSTOMER



SMCS -

## Prestart Checks

### Walk-Around Inspection

Perform required Daily and other periodic maintenance before starting the engine. Make a walk-around inspection of the installation. It only takes a few minutes to make minor corrections. This can prevent major repairs at a later date.

- \* For maximum service life of your engine, make a thorough inspection before starting the engine. Look for items such as oil or coolant leaks, loose bolts, and trash build-up. Remove trash build-up and have repairs made as needed.
- \* Inspect the radiator hoses for cracks and loose clamps.
- \* Inspect the fan belts and accessory drive belts for cracks, breaks, and other damage.
- \* Inspect the wiring for loose connections and for worn or frayed wires.
- \* Check the fuel supply. Drain water from the water separator (if equipped). Open the fuel supply valve.

### NOTICE

**All valves in fuel return line must be open before and during engine operation to prevent high fuel pressure. High fuel pressure may cause filter housing failure or other damage.**

If the engine has not been run for several weeks, fuel may have drained and allowed air into the filter housing. Also, when fuel filters have been changed, some air space will be left in the housing. In these instances, prime the fuel system. Refer to Priming the Fuel System in this publication for more information.

## ⚠ WARNING

**Diesel engine exhaust contains products of combustion which may be harmful to your health. Always start and operate the engine in a well-ventilated area and, if in an enclosed area, vent the exhaust to the outside.**

- \* Do not start the engine or move any of the controls if there is a DO NOT OPERATE or similar warning tag attached to the start switch or controls.
- \* Before starting the engine, the operator must be satisfied that no one will be endangered before and when starting the engine.

\* Some battery chargers are designed to be connected during engine cranking. Some battery chargers are designed to be disconnected during engine cranking. Disconnect the battery charger (if equipped with a charger designed to be disconnected during cranking).

- \* Reset any shutoff or alarm components.
- \* Check for damaged or missing guards. Repair or replace any damaged or missing guards.

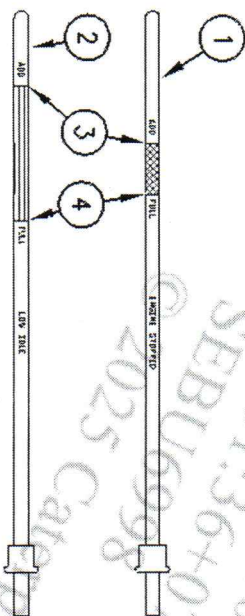

D46561

- Oil Level Gauge (Dipstick): ENGINE STOPPED side (1), LOW IDLE side (2), ADD mark (3), and FULL mark (4).
- \* Check the oil level. The ENGINE STOPPED side of the dipstick is marked to read when the engine is stopped. The LOW IDLE side of the dipstick is marked to read when the engine is at low idle. Maintain the oil level between the ADD and FULL marks.

\* Check the coolant level. Make sure the engine is cool. Remove the radiator or expansion tank filler cap slowly to relieve any pressure. Maintain the coolant to within 13mm (1/2 inch) of the bottom of the fill pipe.

\* Observe the air cleaner service indicator (if equipped). Service the air cleaner when the yellow diaphragm enters the red zone, or the red piston locks in the visible position.

### Starting, Operating and Stopping Engines Equipped with Control Panels

For information regarding the generator control panel used for starting, operating and stopping the engine, refer to SEBU6918, SR4B Generators and Control Panels, or refer to SENU6918, 130-3786 Generator Set Control Panel Supplement. Additional information and programming instructions are provided in the Service Manual for your specific control panel.



- Air Starter showing Air Valve (1) and Lubricator Bowl (2)
- 3. Check the oil level in the lubricator bowl (2). Keep the bowl at least half full and add lubricant if necessary.
- 4. Push the air valve (1) or the engine start button to crank the engine. Release the valve or button as soon as the engine starts.

### Cold Weather Starting Aids



Personal injury or death can result from using ether.

Personal injury or property damage can result from alcohol or starting fluids. Alcohol or starting fluids are highly flammable and toxic and if improperly stored could result in injury or property damage.

When using starting fluid, follow the manufacturer's instructions carefully. Use ether sparingly and spray it only while cranking the engine.

Failure to follow these instructions could result in an explosion and/or fire and possible personal injury.

### NOTICE

Excessive ether can cause piston and ring damage. Use ether for cold starting purposes only. Do not use excessive starting fluid during starting or after the engine is running.

Caterpillar engines are designed to start without starting aids at temperatures greater than 12°C (55°F). At least one of the following conditions may be necessary in order to start the engine at colder temperatures:

- \* the use of a jacket water and/or crankcase oil heater.
- \* additional volume in the air tank for air starting systems.
- \* greater pressure for air starting systems.

- \* extra battery capacity for electric starting.
- \* spraying starting fluid into the air inlet.
- \* injecting ether into the air inlet.

To start engines equipped with an ether injector:

1. Press the ether aid switch for three seconds.

2. Release the switch before performing Step 3 in the Electric Starting procedure.

Additional ether injections may be required to achieve low idle speed. Allow the engine to run at low idle until the engine runs smoothly. Allow the white smoke to disperse before proceeding with normal operation.

Optional jacket water heaters can be provided to maintain the minimum temperature when the engine is not running. Immersion heaters are not recommended for crankcase oil heating. Consult with your Caterpillar dealer about starting at temperatures below -18°C (0°F).

PCP-00022950  
 2025/12/30  
 01:31:22+07:00  
 SEBU69980013  
 © 2025 Caterpillar Inc.



If the installation is not equipped with a backup battery system, an external electrical source may be required for starting.

Many batteries which are considered unusable are still rechargeable. Severely discharged maintenance free batteries might not fully recharge from the alternator alone after jump starting. The batteries must be charged to the proper voltage with a battery charger. For complete information on testing and charging, refer to SEHS7633, the Battery Test Procedure. The Special Instruction is available from your Caterpillar dealer.

Engines installed without engine-to-frame ground straps can be damaged by electrical discharge.

In order to prevent electrical discharge damage, make sure the engine's electrical system has an engine-to-frame ground strap.

For engines which have the alternator connected to an engine component, the ground strap must connect that component to the frame.

Some engines have starter-to-frame ground straps. Many of these starters have electrical insulation systems and are not electrically grounded to the engine. For this reason, the starter-to-frame ground strap may not be an acceptable engine ground.

If the engine is not electrically connected directly to the rails through mounting bolts, install a separate ground strap. Refer to the Electrical Schematic for your engine, or consult with your Caterpillar dealer.

Your engine has a 24 volt starting system. Use only the same voltage for boost starting. Use of a welder or higher voltage will damage the electrical system and is not recommended.

Refer to the following instructions to properly jump start the engine.

## NOTICE

When using an external electrical source to start your engine: turn the START switch off, remove the key, and turn off all electrical accessories before attaching cables.

When using jumper cables always connect the POSITIVE (+) cable to the POSITIVE (+) terminal of the battery connected to the starter solenoid. Connect the NEGATIVE (-) cable from the external source to the starter NEGATIVE (-) terminal. If not equipped with a starter NEGATIVE terminal, connect to the engine block.

**Do not reverse the battery cables. The alternator can be damaged. Attach the ground cable last and remove first.**

1. Connect one end of the cable to the POSITIVE (+) terminal of the battery being started. Connect the other end to the POSITIVE (+) terminal of the power source.
2. Connect one end of the other cable to the NEGATIVE (-) terminal of the power source. Connect the other end to the starter NEGATIVE (-) terminal or to the engine block. This prevents potential sparks from igniting combustible gases produced by some batteries.

3. Start the engine.

4. After the engine starts, disconnect the cable from the starter NEGATIVE (-) terminal or engine block. Disconnect the other end from the NEGATIVE (-) terminal of the power source.

5. Disconnect the cable from the POSITIVE (+) terminal of the battery on the engine being started. Disconnect the cable from the POSITIVE (+) terminal of the power source.

## Air Starting

For good life of the air starting motor, the air supply must be free of dirt and water. A lubricator must be used with the starting system. Use non detergent 10W engine oil for temperatures above 0°C (32°F). Use air tool oil for temperatures below 0°C (32°F).

1. Open and close the drain valve on the bottom of the air tank to drain condensation and oil carryover.
2. Check the air supply pressure. The air starting motor requires a minimum of 690 KPa (100 psi) air pressure to operate properly. The maximum air pressure must not exceed 1550 KPa (225 psi). The normal air pressure will be 758 to 965 KPa (110 to 140 psi).

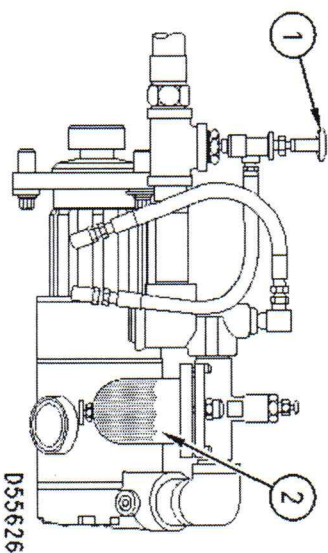



## Electric Starting

**NOTE:** Startability will be improved at temperatures below 12°C (55°F) by the use of a starting aid. A jacket water (coolant) heater or other means can be used to heat the crankcase oil.

### NOTICE

**Do not crank the engine for more than 30 seconds. Allow the starter motor to cool for two minutes before cranking again.**

If the engine does not start within ten seconds, move the governor control lever to the FUEL OFF position. Crank the engine for another ten seconds to clear the cylinders of unburned fuel.

Start the engine using the following procedure:

### Manual Starting

**NOTE:** If the Engine Control Switch is in the AUTO position, the engine will automatically start when a remote start/stop contact is closed. The engine will accelerate to rated speed within a programmed warm-up cycle when the oil pressure sensors indicate there is sufficient oil pressure for rated speed.

1. Perform all prestart checks.
2. Open the main electrical circuit breaker.
3. Depending upon your equipment:

- \* turn the manual speed potentiometer (if equipped) fully counterclockwise.
- \* move the governor control lever to idle speed.

This will allow the engine to run at a low speed. The GSC will allow the engine to be run at rated speed when the oil pressure sensors indicate sufficient pressure for rated speed.

**NOTE:** If the engine idle speed is below 1200 rpm for an extended period of time, the generator voltage regulator may shut off. The voltage regulator will reset automatically when the generator set is completely shut off.

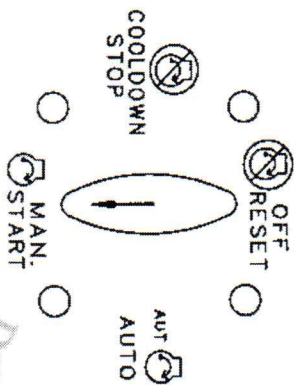

Engine Control Switch (ECS), shown at the MAN. START position.

4. Depending on your type of starting controls:
  - \* turn the starter switch to START position, or
  - \* turn the ECS to the MAN. START position.

### Starting From An External Power Source

#### ⚠ WARNING

- Batteries give off flammable fumes that can explode.
- Improper jumper cable connections can cause an explosion resulting in personal injury. Do not allow jump start cable ends to contact each other or the engine.
- Prevent sparks near the batteries. Sparks could cause vapors to explode. Do not allow jumper cable ends to contact each other or the engine.
- Do not smoke when observing the battery electrolyte levels.
- Always wear protective glasses when working with batteries.
- Electrolyte is an acid and can cause personal injury if it contacts skin or eyes.

First, determine the reason it is necessary to start with power from an external source. Refer to SEHS7668 for information on using the 6V2150 Starting/Charging Analyzer Group.

