

**Demonstrate Selecting, Using and Maintaining a range of Precision and Non-Precision Tools to Accurately Measure**

Skill Number CO-OP15GN105

Full Name: ZAYED SYAMIQ A.

No ID: \_\_\_\_\_

Validation Date: 31 DECEMBER 2025

School: SMKN 1 SINGGAR

**PERFORMANCE TASK:**

Given some measuring tools, the student is requested to perform the following tasks on various measuring tools:

- Selecting
- Using
- Recording
- Maintaining

The student will be instructed to measure with a non-precision gauge such as: steel ruler, feeler gauge and precision tools such as vernier callipers, outside, inside and depth micrometer the dimension of some given parts. Literature and measuring tools will be made available but will not be provided directly to the student.

The student must be able to perform the following task:

- Demonstrate using various measuring tools on an engine or other system components.

Safety and Contamination Control must be always applied to this process.

Prerequisite	Yes	No	N/A	Hints
The student must complete the knowledge assessment. Minimum passing grade 80%.	✓			Score measuring tools Course or subject.

Tasks	Completed			Observation / Hints
	Yes	No	N/A	
Preparation				
Prepare related literature	✓			
Prepare required equipment	✓			
Prepare related tools	✓			
Prepare Safety & Contamination Control equipment	✓			

Tasks	Completed			Observation / Hints
	Yes	No	N/A	
Perform etiquette/manner when starting the job				
Meet the customer / assessor	✓			
Perform etiquette/manner when opening the interaction.	✓			• Perform smile & greetings. • Introduce Student's Identity
Explain the purpose of Student's activity.	✓			
Ask permission to perform the job.	✓			

Tasks	Completed			Observation / Hints
	Yes	No	N/A	
<b>Selecting, Using and Maintaining a range of Precision and Non-Precision Tools</b>				
1. Inspect the measuring tool before using	✓			Visual inspection of the measuring tool for wear, cracks, damage
2. Clean tool and component	✓			Using of consumables CC tools
3. Calibrate measuring tools before using	✓			Tools should be calibrated as given procedure
4. Measure component use measuring tools with tolerance allowance 0.5 mm (0.02" or 1/25") for non-precision measuring tools and 0.025 mm (0.001") for precision measuring tools.	✓			Thread identification gauge and tire pressure gauge without tolerance
5. Tasks completed without damage to equipment and tools	✓			Component and tooling are cleaned and assembled as given procedure
6. Equipment and tooling are cleaned and returned to its correct location	✓			Cleaned and stored equipment tools on the right place.
7. Record the reading of the measurements	✓			Write the actual reading on the paper given by the assessor
<b>Documentation:</b>				
Take picture if needed	✓			



Tasks	Completed			Observation / Hints
	Yes	No	N/A	
Perform close the job by ensuring all systems or conditions is in the standard condition				
Ensure all systems or conditions are in standard condition.	✓			<ul style="list-style-type: none"> <li>Find the improper condition.</li> <li>Communicate the finding to the customer/assessor.</li> </ul>

Tasks	Completed			Observation / Hints
	Yes	No	N/A	
All relevant documentation completed correctly and approved by customer (if required).	✓			<ul style="list-style-type: none"> <li>Completing the Task List</li> <li>Completing Measurement Form/Related Check Sheet, if required</li> <li>Create Service Report (SIMS), if required</li> <li>Create SPR, if required</li> <li>Documenting the failed or damaged parts, if required</li> <li>Provide Technical Analysis Report/Failure Analysis Report, if required.</li> </ul>

Tasks	Completed		Observation / Hints
	Yes	No	
Safety			
Using PPE related to the job	✓		
Follows relevant Workplace Safety Guidelines (LOTO, Safety Equipment)	✓		Comply with safety regulation that applied on the workplace
State and follow Safety Precautions	✓		<ul style="list-style-type: none"> <li>Create Job Safety Analysis</li> <li>Student must follow safety procedure refer to service manual or SIS related to job</li> </ul>
Service man completes job without accident due to incorrect procedure using hand tools.	✓		<ul style="list-style-type: none"> <li>Correct working position</li> <li>Correct hand tool related to the job</li> </ul>
Tasks completed without damage equipment and tools	✓		

Tasks	Completed			Observation / Hints
	Yes	No	N/A	
Contamination Control				
Environmental Practices & Housekeeping	✓			<ol style="list-style-type: none"> <li>Waste is minimized, waste material, including sludge, solids and other wastes are sorted and stored in bins for recycling or disposal</li> <li>Packaging of goods received is sorted and reused or disposed of by recycling</li> <li>Materials that can be reused are cleaned and stored</li> <li>Waste and scrap are removed following workplace procedures</li> <li>All fluids are disposed of in accordance with enterprise policies and procedures</li> </ol>

Tasks	Completed			Observation / Hints
	Yes	No	N/A	
Perform etiquette/manner after completing the job				
Perform etiquette/manner when closing the communication.	✓			<ul style="list-style-type: none"> <li>Perform smile &amp; greetings.</li> <li>Ask permission to leave or end the interaction.</li> </ul>



General Comments

RESULT: COMPETENT  NOT YET COMPETENT  (please check (N))

Student: ZAYED SYAMIQ A  
Name: ZAYED SYAMIQ A Date: 31 Desember 2025  
Signature: 

Assessor: Setiawan Tuh U  
Name: Setiawan Tuh U Date: 31 Desember 2025  
Signature: \_\_\_\_\_

Supervisor: \_\_\_\_\_  
Name: \_\_\_\_\_ Date: \_\_\_\_\_  
Signature: \_\_\_\_\_

Data Recorded: \_\_\_\_\_  
Name: \_\_\_\_\_ Date: \_\_\_\_\_  
Signature: \_\_\_\_\_



**Demonstrate Selecting, Using and Maintaining a range of Precision and Non-Precision Tools to Accurately Measure**

Skill Number CO-OP15GN105

Full Name: Zayed Syarif A.

No ID: \_\_\_\_\_

Validation Date: 31 DECEMBER 2025 School: SMKN 1 SINGOSARI

**PERFORMANCE TASK:**

Given some measuring tools, the student is requested to perform the following tasks on various measuring tools:

- Selecting
- Using
- Recording
- Maintaining

The student will be instructed to measure with a non-precision gauge such as: steel ruler, feeler gauge and precision tools such as vernier callipers, outside, inside and depth micrometer the dimension of some given parts. Literature and measuring tools will be made available but will not be provided directly to the student.

The student must be able to perform the following task:

- Demonstrate using various measuring tools on an engine or other system components.

Safety and Contamination Control must be always applied to this process.

Prerequisite	Yes	No	N/A	Hints
The student must complete the knowledge assessment. Minimum passing grade 80%.	✓			

Tasks	Completed			Observation / Hints
	Yes	No	N/A	
Preparation	✓			
Prepare related literature	✓			
Prepare required equipment	✓			
Prepare related tools	✓			
Prepare Safety & Contamination Control equipment	✓			

Tasks	Completed			Observation / Hints
	Yes	No	N/A	
Perform etiquette/manner when starting the job	✓			
Meet the customer / assessor	✓			
Perform etiquette/manner when opening the interaction.	✓			
Explain the purpose of Student's activity.	✓			
Ask permission to perform the job.	✓			

Tasks	Completed			Observation / Hints
	Yes	No	N/A	
<b>Selecting, Using and Maintaining a range of Precision and Non-Precision Tools</b>				
1. Inspect the measuring tool before using	✓			
2. Clean tool and component	✓			
3. Calibrate measuring tools before using	✓			
4. Measure component use measuring tools with tolerance allowance 0.5 mm (0.02" or 1/25") for non-precision measuring tools and 0.025 mm (0.001") for precision measuring tools.	✓			
5. Tasks completed without damage to equipment and tools	✓			
6. Equipment and tooling are cleaned and returned to its correct location	✓			
7. Record the reading of the measurements	✓			
<b>Documentation:</b>				
Take picture if needed	✓			



Tasks	Completed			Observation / Hints
	Yes	No	N/A	
Perform close the job by ensuring all systems or conditions is in the standard condition	✓			
Ensure all systems or conditions are in standard condition.	✓			

Tasks	Completed			Observation / Hints
	Yes	No	N/A	
Reporting				
All relevant documentation completed correctly and approved by customer (if required).	✓			

Tasks	Completed			Observation / Hints
	Yes	No	N/A	
Safety				
Using PPE related to the job	✓			
Follows relevant Workplace Safety Guidelines (LOTO, Safety Equipment)	✓			
State and follow Safety Precautions	✓			
Serviceperson completes job without accident due to incorrect procedure using hand tools.	✓			
Tasks completed without damage equipment and tools	✓			

Tasks	Completed			Observation / Hints
	Yes	No	N/A	
Contamination Control				
Environmental Practices & Housekeeping	✓			

Tasks	Completed			Observation / Hints
	Yes	No	N/A	
Perform etiquette/manner after completing the job	✓			
Perform etiquette/manner when closing the communication.	✓			

General Comments

RESULT: COMPETENT  NOT YET COMPETENT  (please check (N))

Student: ZAYED SYAVIQ A. 21 December 2025

Assessor: SETIAWAN TUHIV 31 December 2025

Supervisor: \_\_\_\_\_ Date \_\_\_\_\_

Data Recorded: \_\_\_\_\_ Date \_\_\_\_\_

PS  
GI  
BE  
Va  
U  
SK

### Demonstrate Selecting, Using and Maintaining Various Special Tools Correctly

Number CO-OP15GN104

Name: \_\_\_\_\_ No ID: \_\_\_\_\_  
 Date: \_\_\_\_\_ School: \_\_\_\_\_

**PERFORMANCE TASK:**

In some special tools, the student is requested to perform the following tasks:

- Selecting, using, maintaining various Special Tools in the installation of Engine or other system components.
- Perform close the job by ensuring all systems or conditions is in the standard condition.

Safety and Contamination Control must be applied to this process. All literatures will be available.

Prerequisite	Completed			Hints
	Yes	No	N/A	
student must complete the knowledge assessment. minimum passing grade 80%.				Score special tools Course or subject.

Tasks	Completed			Observation / Hints
	Yes	No	N/A	
Prepare related literature				
Prepare required equipment				
Prepare related tools				
Prepare Safety & Contamination Control				

Tasks	Completed			Observation / Hints
	Yes	No	N/A	
Perform etiquette/manner when starting the job				
Meet the customer / assessor				
Perform etiquette/manner when opening the interaction.				<ul style="list-style-type: none"> <li>Perform smile &amp; greetings.</li> <li>Introduce Student's identity</li> </ul>
Explain the purpose of Student's activity.				
Ask permission to perform the job.				

Tasks	Completed			Observation / Hints
	Yes	No	N/A	
<b>Selecting, Using and Maintaining Various Special Tools</b>				
1. Inspect the Special Tool before using				Visual inspection of the Special Tool for wear, cracks, damage
2. Calibrate the special tool before using				<ul style="list-style-type: none"> <li>Torque wrench</li> </ul>
3. Remove and install or disassemble and assemble conducted according to correct procedures				Equipment and tooling are identified and checked for safe and effective operation and must refer to Service manual or SIS
4. Tasks completed without damage to equipment and tools				Component and tooling are cleaned and stored on the right place
5. Equipment and tooling is cleaned and returned to its correct location				Cleaned and stored equipment tools on the right place.
6. Work area left clean and tidy				Area cleaned from spills and wastes.
<b>Documentation:</b>				
Take picture if needed				

Tasks	Completed			Observation / Hints
	Yes	No	N/A	
<b>Perform close the job by ensuring all systems or conditions is in the standard condition</b>				
Ensure all systems or conditions are in standard condition.				<ul style="list-style-type: none"> <li>Find the improper condition.</li> <li>Communicate the finding to the customer/assessor.</li> </ul>

**ANALISIS LINGKUNGAN KESELAMATAN KERJA / JOB SAFETY ENVIRONMENT ANALYSIS**

Pekerjaan / Task	DA GEAR PUMP	Nomor JSEA / JSEA Number	01	Halaman / Page	1	Dari / Of	2
Tanggal Pembuatan JSEA / Date of JSEA	31 Desember 2025	Departemen / Dept	SERVICE	Tempat Kerja / Work Location	WORKSHOP TAB		
Disusun Oleh / Compiled By	ZAYED	TTD / Sign		Review Oleh / Reviewed By		TTD / Sign	
Atasan / Superior		TTD / Sign		Atasan / Superior		TTD / Sign	

Apakah Anda sudah terlatih untuk melakukan pekerjaan ini? / Are you properly trained to complete these task?  Ya / Yes  Tidak / No

Apakah Anda memerlukan peralatan LOTO? / Are you need LOTO Equipments?  Ya / Yes  Tidak / No

Apakah Anda mengetahui ERP/MERP dari pekerjaan yang sedang dilakukan?  Ya / Yes  Tidak / No *Jika tidak, silahkan tambahkan dalam urutan langkah tugas diawal*

Kondisi Lingkungan / Environmental Conditions	Cuaca / Weather	Medan / Terrain
Pengendalian Sumber Bahaya / Hazardous Energy Control <input type="checkbox"/> Listrik / Electrical <input type="checkbox"/> Hidraulik / Hydraulic	<input checked="" type="checkbox"/> Gravitasi (Benda jatuh,tertipa) / Gravitation (Falling objects, struck down) <input checked="" type="checkbox"/> Mekanis / Mechanical	<input type="checkbox"/> Pneumatik / Pneumatic <input type="checkbox"/> Panas / Thermal
APD yang diperlukan / Required PPE <input checked="" type="checkbox"/> Helm / Safety Helm <input checked="" type="checkbox"/> Sarung Tangan / Hand Gloves <input checked="" type="checkbox"/> Sepatu / Safety Shoes	<input type="checkbox"/> Pelindung Muka / Face shield <input type="checkbox"/> Pelindung Pernafasan / Respiratory Protection <input type="checkbox"/> Pelindung Telinga / Hearing Protection	<input checked="" type="checkbox"/> Kacamata / Safety Glass <input type="checkbox"/> Perlindungan Kejutahan / Fall Protection <input type="checkbox"/> Lain-Lain / Other .....

Hal yang perlu dipertimbangkan dalam mengidentifikasi bahaya / These to consider in identify hazards :

1 Bahaya Keselamatan : Kondisi tidak aman yang dapat menyebabkan injury atau kematian seperti terpelesep/terjatuh, tertimpa dll. Safety Hazard : unsafe conditions that can cause injury or even death, such as spill/falls, pinch point, struck by, etc.	4 Bahaya Biologi : Patogen yang ditularkan melalui darah, jamur, tanaman/serangga/hewan. Biological Hazards : bloodbone pathogens, mold, Plant/Insect/Animals
2 Bahaya Fisik : Listrik, Apiledakan, Kebisingan, Radiasi, Panas, Tekanan, Terjepit, Tersandung/Terjatuh, Tertimpa, Getaran. Physical Hazards : Electrical, Fire/Explosion, Noise, Radiations, Thermal, Pressure, Pinch Point, Slips/Falls, Struck by, Vibration.	5 Bahaya Ergonomi : Gerakan berulang-ulang, beban yang berlebihan, Postur Janggal, Durasi kerja, Desain area kerja. Ergonomic Hazards : Repetitions, Forcefull extention, Awkward Posture, Duration , Work area desain.
3 Bahaya Kimia : Terhirup, terkena kulit, injeksi, tertelan, terserap. Chemical Hazards : Inhalation, skin contact, injection, ingestion, absorption.	6 Bahaya Organisasi : stres atau bahaya terkait dengan masalah tempat kerja yang menyebabkan efek jangka panjang atau pendek, beban kerja yang berat dan kekerasan ditempat kerja. Organizational hazards : stressors or hazards associated with workplace issues that cause long or short term effects heavy workloads, stressful interactions and workplaces violence.

No	Urutan Dasar Langkah Tugas / Job Steps (* Maksimum 15 Langkah / Maximum 15 Steps)	Bahaya Yang Terkait / Potential Hazard(s)	Tindakan Perbaikan / Recommended Action
1.	Prepare APD	1.1 Tersandung Meja	1.1.1 Pindahkan Meja agar tidak menghalangi 1.1.2 Gunakan safety shoes
2.	Walk around inspection	2.1 Tersandung Meja 2.2 Terpelesep	2.1.1 Fokus saat bekerja 2.1.2 Gunakan safety shoes 2.2.1 Gunakan APD lengkap 2.2.2 Bersihkan menggunakan white towel
3.	Prepare tools vernier $\frac{1}{8}$ & $\frac{1}{16}$	3.1 Terjepit laci toolbox 3.2 Toolbox menabrak benda lain 3.3 Kaki terlindas tool box	3.1.1 Perhatikan area pegangan yang aman 3.1.2 Gunakan safety gloves 3.2.1 Jangan bergurau 3.3.1 Gunakan safety shoes
4.	Doing Disassembly Gear Pump	4.1 Tergores komponen 4.2 Jari terjepit komponen 4.3 Kaki tertimpa tool	4.1.1 Hindari area tajam 4.1.2 Gunakan safety gloves 4.2.1 Hindari titik jepit 4.2.2 Gunakan safety gloves 4.3.1 Pegang tool dengan benar 4.3.2 Fokus saat bekerja 4.3.3 Gunakan safety shoes
5.	Measure the component	5.1 Tergores vernier caliper	5.1.1 Hindari area yang tajam







01/08/1985

Engine Oil Pump  
(9S1195 and 9S1575) (REG01547)

PCP-00022950

2025/12/31

05:00:24+07:00

REG015470035

© 2025 Caterpillar Inc.

SMCS -

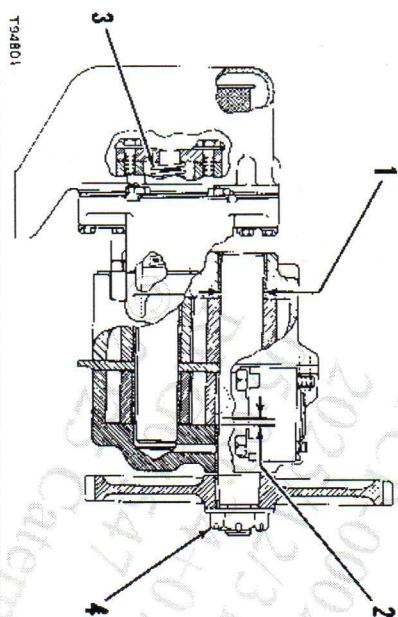

9S1195 SHOWN

(1) Diameter of shaft ... 1.2278 ± .0003 in.(31.186 ± 0.008 mm) — micro 1" +

Bore in bearings ... 1.2305 ± .0005 in.(31.255 ± 0.013 mm)

Maximum permissible clearance between bearings and shaft (worn) ... .005 in.(0.13 mm)

(2) Clearance between gear and cover ... .003 ± .001 in.(0.08 ± 0.03 mm)

(3) Oil pressure to open relief valve ... 72 ± 4 psi(5.0 ± 0.3 kg/cm<sup>2</sup>)

(3) 2S2760 Spring for relief valve:

Length under test force ... 4.64 in.(117.86 mm)

Test force ... 110 ± 5.5 lb.(49.9 ± 2.5 kg)

Free length after test ... 6.02 in.(152.9 mm)

Outside diameter ... 1.063 in.(27.00 mm)

(4) Torque for nut (9S1195 Pump) ... 100 lb. ft.(13.8 mkg)

Tighten more to get alignment for cotter pin.

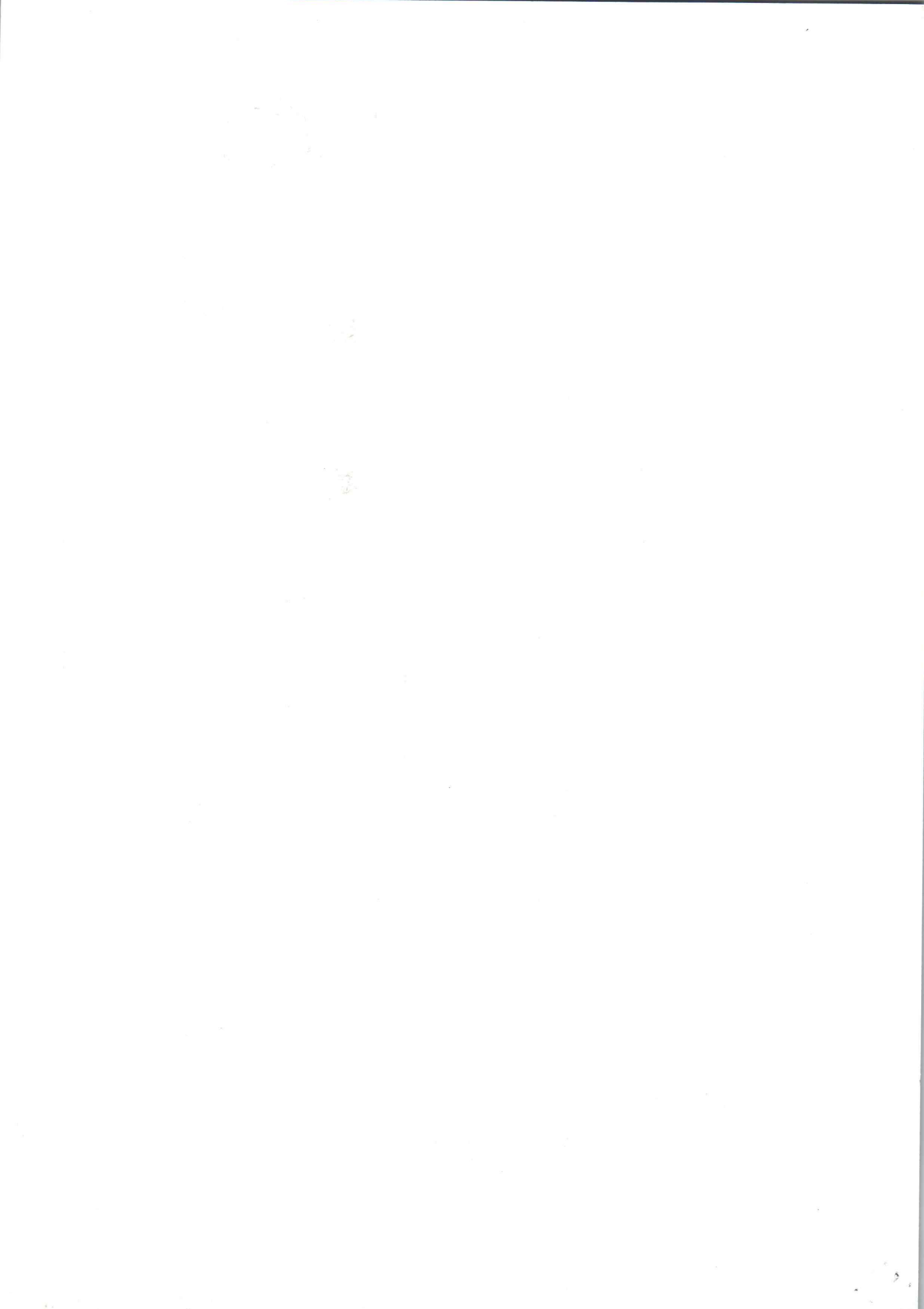

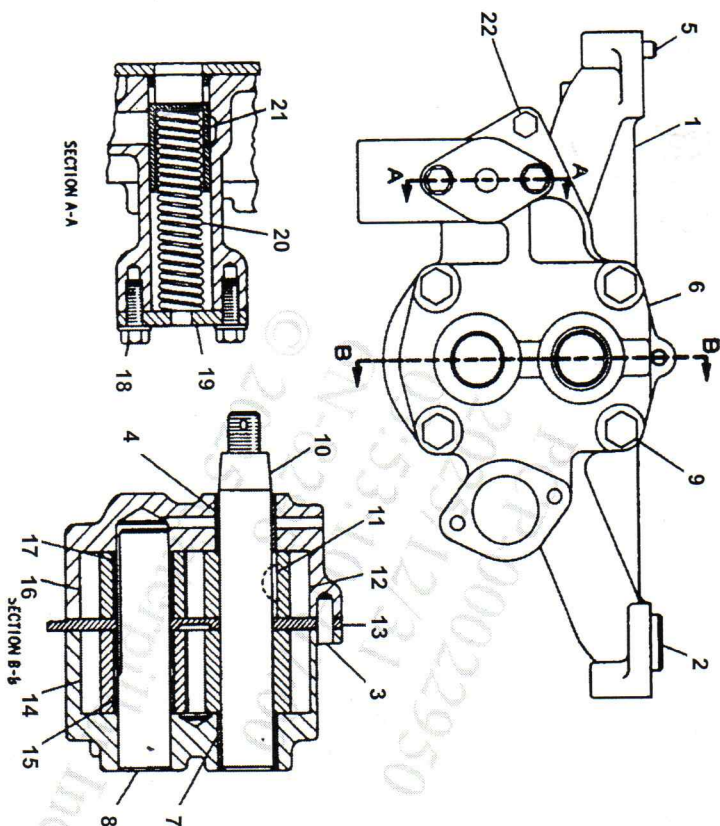

6N8298 OIL PUMP GROUP  
 Serial No. 43N1173-Up and Engine Serial No.  
 52K1-Up  
 Part of 1M7037 Oil Pump Group shown on Page  
 49B

Image #	Callout #	Part Number	Part Name	Quantity
		<b>Group Part</b>		
		6N-8298	Oil Pump Group	
Part List Items				
1	1	6N-8299	Body Assem.	1
(Includes)				
1	2	2M-4072	Dowel	1
1	3	5B-5821	Dowel	1
1	4 RRP	2H-2356	Bearing	1
1	5	5B-5812	Dowel	1
1	6	6N-8311	Body Assem.	1
(Includes)				
1	7 RRP	1H-0030	Bearing	1
1	8	2M-1433	Shaft	1
1	9	1D-4566	Bolt	4
1	10	6N-8309	Shaft Assem.	1
(oil pump drive - 9 teeth)				
1	11 RRP	1B-8709	Key	1
1	12	6N-8312	Gear	1
(scavenge pump drive - 9 teeth)				
1	13	6N-8303	Spacer	1
1	14	6N-8308	Gear Assem.	1
(oil pump idler - 9 teeth)				
(Includes)				
1	15 RRP	3H-2512	Bearing	2
1	16	6N-8301	Gear Assem.	1
(scavenge pump idler - 9 teeth)				
(Includes)				
1	17 RRP	4M-9920	Bearing	1
1	18	0L-1351	Bolt	2
		5M-2894	Washer	2
1	19	8M-5434	Flange Assem.	1
1	20 RRP	2S-2760	Spring	1
1	21	2S-2781	Plunger	1
1	22	0T-0573	Bolt	1

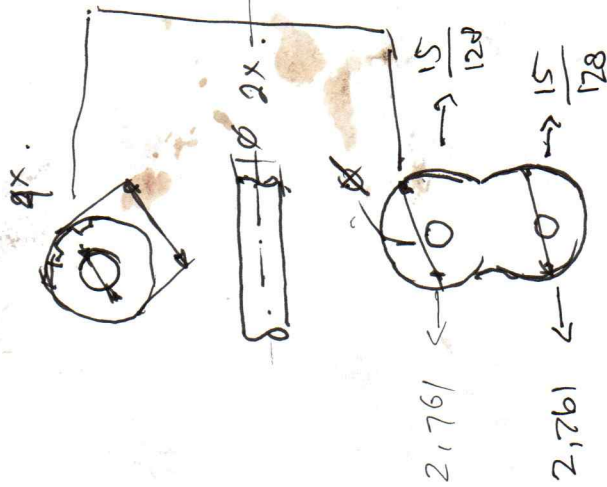

clearance  
 Shaft  
 Gear

2,795 1,2  
 2,791  
 2,725.  
 14  
 2,789.

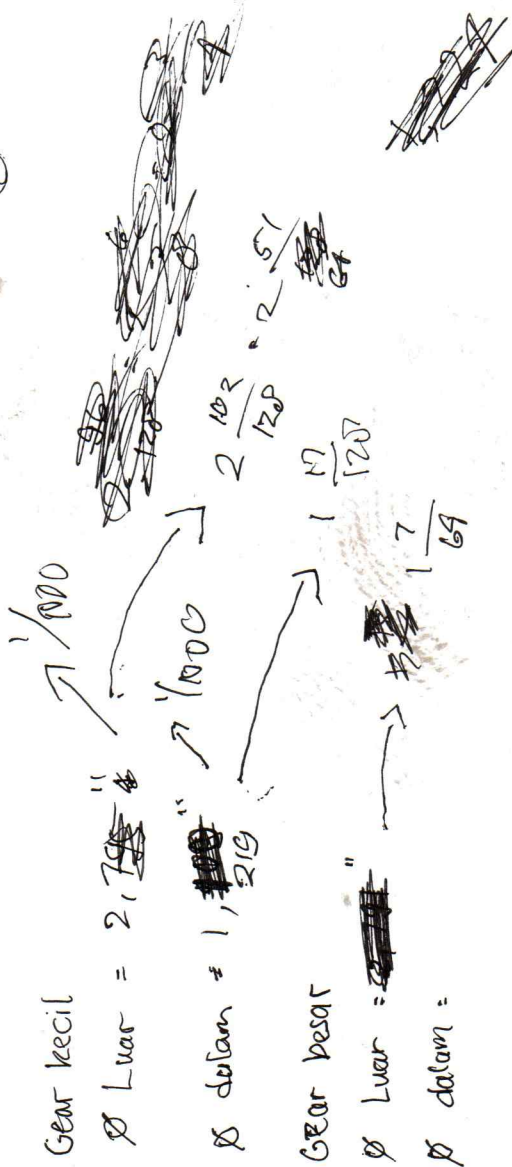

Gear kecil

$\varnothing$  Luar = 2,795"

$\varnothing$  dalam = 2,791"

Gear besar

$\varnothing$  Luar = 2,725"

$\varnothing$  dalam = 2,789"

Gear kecil

$\varnothing$  Luar = 2,795"

=  $2 \frac{51}{69}$

$\varnothing$  dalam = 2,791"

=  $1 \frac{17}{120}$

Gear Besar

$\varnothing$  luar =  $2 \frac{91}{128}$

= 2,757

$\varnothing$  dalam =  $1 \frac{13}{69}$

= 1,220