

Demonstrate Selecting, Using and Maintaining a range of Precision and Non-Precision Tools to Accurately Measure

Skill Number CO-OP15GN105

Full Name: Ushah Muthinda S

No ID: _____

Validation Date: 31 December 2022

School: _____

PERFORMANCE TASK:

Given some measuring tools, the student is requested to perform the following tasks on various measuring tools:

- Selecting
- Using
- Recording
- Maintaining

The student will be instructed to measure with a non-precision gauge such as: steel ruler, feeler gauge and precision tools such as vernier calipers, outside, inside and depth micrometer the dimension of some given parts. Literature and measuring tools will be made available but will not be provided directly to the student.

The student must be able to perform the following task:

- Demonstrate using various measuring tools on an engine or other system components.

Safety and Contamination Control must be always applied to this process.

Prerequisite	Yes	No	N/A	Hints
The student must complete the knowledge assessment. Minimum passing grade 80%.	✓			Score measuring tools Course or subject.

Tasks	Completed			Observation / Hints
	Yes	No	N/A	
Preparation				
Prepare related literature	✓			
Prepare required equipment	✓			
Prepare related tools	✓			
Prepare Safety & Contamination Control equipment	✓			

Tasks	Completed			Observation / Hints
	Yes	No	N/A	
Perform etiquette/manner when starting the job	✓			
Meet the customer / assessor	✓			
Perform etiquette/manner when opening the interaction.	✓			<ul style="list-style-type: none"> • Perform smile & greetings. • Introduce Student's identity
Explain the purpose of Student's activity.	✓			
Ask permission to perform the job.	✓			

Tasks	Completed			Observation / Hints
	Yes	No	N/A	
Selecting, Using and Maintaining a range of Precision and Non-Precision Tools				
1. Inspect the measuring tool before using	✓			Visual inspection of the measuring tool for wear, cracks, damage
2. Clean tool and component	✓			Using of consumables CC tools
3. Calibrate measuring tools before using	✓			Tools should be calibrated as given procedure
4. Measure component use measuring tools with tolerance allowance 0.5 mm (0.02" or 1/25") for non-precision measuring tools and 0.025 mm (0.001") for precision measuring tools.	✓			Thread identification gauge and tire pressure gauge without tolerance
5. Tasks completed without damage to equipment and tools	✓			Component and tooling are cleaned and assembled as given procedure
6. Equipment and tooling are cleaned and returned to its correct location	✓			Cleaned and stored equipment tools on the right place.
7. Record the reading of the measurements	✓			Write the actual reading on the paper given by the assessor
Documentation:				
Take picture if needed	✓			



Tasks	Completed			Observation / Hints
	Yes	No	N/A	
Perform close the job by ensuring all systems or conditions is in the standard condition	✓			<ul style="list-style-type: none"> Find the improper condition. Communicate the finding to the customer/assessor.
Ensure all systems or conditions are in standard condition.	✓			

Tasks	Completed			Observation / Hints
	Yes	No	N/A	
Reporting All relevant documentation completed correctly and approved by customer (if required).	✓			<ul style="list-style-type: none"> Completing the Task List Completing Measurement Form/Related Check Sheet, if required Create Service Report (SMS), if required Create SPR, if required Documenting the failed or damaged parts, if required Provide Technical Analysis Report/Failure Analysis Report, if required.

Tasks	Completed			Observation / Hints
	Yes	No	N/A	
Safety	✓			
Using PPE related to the job	✓			
Follows relevant Workplace Safety Guidelines (LOTO, Safety Equipment)	✓			Comply with safety regulation that applied on the workplace
State and follow Safety Precautions	✓			<ul style="list-style-type: none"> Create Job Safety Analysis Student must follow safety procedure refer to service manual or SIS related to job
Service man completes job without accident due to incorrect procedure using hand tools.	✓			<ul style="list-style-type: none"> Correct working position Correct hand tool related to the job
Tasks completed without damage equipment and tools	✓			

Tasks	Completed			Observation / Hints
	Yes	No	N/A	
Environmental Practices & Housekeeping	✓			<ol style="list-style-type: none"> Waste is minimized, waste material, including sludge, solids and other wastes are sorted and stored in bins for recycling or disposal Packaging of goods received is sorted and reused or disposed of by recycling Materials that can be reused are cleaned and stored Waste and scrap are removed following workplace procedures All fluids are disposed of in accordance with enterprise policies and procedures

Tasks	Completed			Observation / Hints
	Yes	No	N/A	
Perform etiquette/manner after completing the job	✓			
Perform etiquette/manner when closing the communication.	✓			<ul style="list-style-type: none"> Perform smile & greetings. Ask permission to leave or end the interaction.

General Comments

RESULT: **COMPETENT** **NOT YET COMPETENT** (please check (✓))

Student: Vashti Manidra 31/12/25
Name Date Signature

Assessor: Seliana B 21/12/25
Name Date Signature

Supervisor: _____
Name Date Signature

Data Recorded: _____
Name Date Signature

CO-OP

CO-OP15GN105 – Candidate Performance Guide

Demonstrate Selecting, Using and Maintaining a range of Precision and Non-Precision Tools to Accurately Measure

Skill Number CO-OP15GN105

Full Name: Vashti Mawidira S

No ID: _____

Validation Date: 31 December 2025

School: _____

PERFORMANCE TASK:

Given some measuring tools, the student is requested to perform the following tasks on various measuring tools:

- Selecting
- Using
- Recording
- Maintaining

The student will be instructed to measure with a non-precision gauge such as: steel ruler, feeler gauge and precision tools such as vernier callipers, outside, inside and depth micrometer the dimension of some given parts. Literature and measuring tools will be made available but will not be provided directly to the student.

The student must be able to perform the following task:

- Demonstrate using various measuring tools on an engine or other system components.
- Safety and Contamination Control must be always applied to this process.

Prerequisite	Yes	No	N/A	Hints
The student must complete the knowledge assessment. Minimum passing grade 80%.	<input checked="" type="checkbox"/>	<input type="checkbox"/>	<input type="checkbox"/>	

Tasks	Completed			Observation / Hints
	Yes	No	N/A	
Preparation				
Prepare related literature	<input checked="" type="checkbox"/>	<input type="checkbox"/>	<input type="checkbox"/>	
Prepare required equipment	<input checked="" type="checkbox"/>	<input type="checkbox"/>	<input type="checkbox"/>	
Prepare related tools	<input checked="" type="checkbox"/>	<input type="checkbox"/>	<input type="checkbox"/>	
Prepare Safety & Contamination Control equipment	<input checked="" type="checkbox"/>	<input type="checkbox"/>	<input type="checkbox"/>	



CO-OP

CO-OP15GN105 – Candidate Performance Guide

Tasks	Completed			Observation / Hints
	Yes	No	N/A	
Perform etiquette/manner when starting the job	<input checked="" type="checkbox"/>	<input type="checkbox"/>	<input type="checkbox"/>	
Meet the customer / assessor	<input checked="" type="checkbox"/>	<input type="checkbox"/>	<input type="checkbox"/>	
Perform etiquette/manner when opening the interaction.	<input checked="" type="checkbox"/>	<input type="checkbox"/>	<input type="checkbox"/>	
Explain the purpose of Student's activity.	<input checked="" type="checkbox"/>	<input type="checkbox"/>	<input type="checkbox"/>	
Ask permission to perform the job.	<input checked="" type="checkbox"/>	<input type="checkbox"/>	<input type="checkbox"/>	

Tasks	Completed			Observation / Hints
	Yes	No	N/A	
Selecting, Using and Maintaining a range of Precision and Non-Precision Tools				
1. Inspect the measuring tool before using	<input checked="" type="checkbox"/>	<input type="checkbox"/>	<input type="checkbox"/>	
2. Clean tool and component	<input checked="" type="checkbox"/>	<input type="checkbox"/>	<input type="checkbox"/>	
3. Calibrate measuring tools before using	<input checked="" type="checkbox"/>	<input type="checkbox"/>	<input type="checkbox"/>	
4. Measure component use measuring tools with tolerance allowance 0.5 mm (0.02" or 1.25") for non-precision measuring tools and 0.025 mm (0.001") for precision measuring tools.	<input checked="" type="checkbox"/>	<input type="checkbox"/>	<input type="checkbox"/>	
5. Tasks completed without damage to equipment and tools	<input checked="" type="checkbox"/>	<input type="checkbox"/>	<input type="checkbox"/>	
6. Equipment and tooling are cleared and returned to its correct location	<input checked="" type="checkbox"/>	<input type="checkbox"/>	<input type="checkbox"/>	
7. Record the reading of the measurements	<input checked="" type="checkbox"/>	<input type="checkbox"/>	<input type="checkbox"/>	
Documentation:				
Take picture if needed	<input checked="" type="checkbox"/>	<input type="checkbox"/>	<input type="checkbox"/>	



Tasks	Completed		Observation / Hints
	Yes	No	
Perform close the job by ensuring all systems or conditions is in the standard condition	✓		
Ensure all systems or conditions are in standard condition.	✓		

Tasks	Completed			Observation / Hints
	Yes	No	N/A	
Reporting	✓			
All relevant documentation completed correctly and approved by customer (if required).				

Tasks	Completed		Observation / Hints
	Yes	No	
Safety	✓		
Using PPE related to the job	✓		
Follows relevant Workplace Safety Guidelines (LOTO, Safety Equipment)	✓		
State and follow Safety Precautions	✓		
Service technician completes job without accident due to incorrect procedure using hand tools.	✓		
Tasks completed without damage equipment and tools	✓		

Tasks	Completed		Observation / Hints
	Yes	No	
Contamination Control	✓		
Environmental Practices & Housekeeping			

Tasks	Completed			Observation / Hints
	Yes	No	N/A	
Perform etiquette/manner after completing the job	✓			
Perform etiquette/manner when closing the communication.	✓			

CO-OP
 CO-OP15GN105 - Candidate Performance Guide
 General Comments

RESULT: COMPETENT NOT YET COMPETENT (please check 'N')

Student: Nash Mawdrin 31/12/25

Assessor: Schauer TB 31/12/25

Supervisor: _____ Date: _____ Signature: _____

Data Recorded: Name: _____ Date: _____ Signature: _____





ANALISIS LINGKUNGAN KESELAMATAN KERJA / JOB SAFETY ENVIRONMENT ANALYSIS

Pekerjaan / Task	DA GEAR PUMP.	Nomor JSEA / JSEA Number	Halaman / Page	Dari / Of
Tanggal Pembuatan JSEA / Date of JSEA	31 - 12 - 2025	Departemen / Dept	Tempat Kerja / Work Location	Workshop TAB
Disusun Oleh / Compiled By	Vashti	TTD Sign	Review Oleh / Reviewed By	TTD Sign
Atasan / Superior		TTD Sign		

Apakah Anda sudah terlatih untuk melakukan pekerjaan ini ? / Are you properly trained to complete these task ? Ya / Yes Tidak / No

Apa yang Anda perlukan untuk memastikan bahwa pekerjaan selesai tanpa adanya kecelakaan kerja ? / What do you need to ensure this job is completed incident free ?

Tools yang digunakan sudah sesuai dengan Manual

Siapa yang bertanggung jawab untuk menghentikan pekerjaan jika terjadi perubahan pekerjaan atau gangguan kondisi lingkungan kerja ? / Who is responsible for Stop Work Authority if change job or workplace distraction could ?

ABCD-1 (Technician Leader) / Mr. X (Customer)

Apakah Anda memerlukan peralatan LOTO ? / Are you need LOTO Equipments ? Ya / Yes Tidak / No

Apakah Anda mengetahui ERP/MERP dari pekerjaan yang sedang dilakukan? Ya / Yes Tidak / No *Jika tidak, silahkan tambahkan dalam urutan langkah tugas diawal*

Kondisi Lingkungan / Environmental Conditions	Cuaca / Weather	Cerah	Medan / Terrain	Rata
---	-----------------	-------	-----------------	------

Pengendalian Sumber Bahaya / Hazardous Energy Control	<input type="checkbox"/> Listrik / Electrical	<input checked="" type="checkbox"/> Gravitasi (Benda jatuh, tertimpa) / Gravitation (Falling objects, struck down)	<input type="checkbox"/> Pneumatik / Pneumatic
	<input type="checkbox"/> Hidraulik / Hydraulic	<input checked="" type="checkbox"/> Mekanis / Mechanical	<input type="checkbox"/> Panas / Thermal

APD yang diperlukan / Required PPE	<input checked="" type="checkbox"/> Helm / Safety Helm	<input type="checkbox"/> Pelindung Muka / Face shield	<input checked="" type="checkbox"/> Kacamata / Safety Glass
	<input checked="" type="checkbox"/> Sarung Tangan / Hand Gloves	<input type="checkbox"/> Pelindung Pernafasan / Respiratory Protection	<input type="checkbox"/> Perlindungan Kejatuhan / Fall Protection
	<input checked="" type="checkbox"/> Sepatu / Safety Shoes	<input type="checkbox"/> Pelindung Telinga / Hearing Protection	<input type="checkbox"/> Lain-Lain / Other

Hal yang perlu dipertimbangkan dalam mengidentifikasi bahaya / These to consider in identify hazards :

<p>1 Bahaya Keselamatan : Kondisi tidak aman yang dapat menyebabkan injury atau kematian seperti terpeleceh, terpeleset/terjatuh, tertimpa dll.</p> <p><i>Safety Hazard : unsafe conditions that can cause injury or even death, such as spill/falls, pinch point, struck by, etc.</i></p>	<p>4 Bahaya Biologi : Patogen yang ditularkan melalui darah, jamur, tanaman/serangga/hewan.</p> <p><i>Biological Hazards : bloodbone pathogens, mold, Plant/Insect/Animals</i></p>
<p>2 Bahaya Fisik : Listrik, Api/ledakan, Kebisingan, Radiasi, Panas, Tekanan, Terjepit, Tersandung/Terjatuh, Tertimpa, Getaran.</p> <p><i>Physical Hazards : Electrical, Fire/Explosion, Noise, Radiations, Thermal, Pressure, Pinch Point, Slips/Falls, Struck by, Vibration.</i></p>	<p>5 Bahaya Ergonomi : Gerakan berulang-ulang, beban yang berlebihan, Postur Janggal, Durasi kerja, Desain area kerja.</p> <p><i>Ergonomic Hazards : Repetitions, Forcefull extention, Awkward Posture, Duration , Work area desain.</i></p>
<p>3 Bahaya Kimia : Terhirup, terkena kulit, injeksi, tertelan, terserap.</p> <p><i>Chemical Hazards : Inhalation, skin contact, injection, ingestion, absorption.</i></p>	<p>6 Bahaya Organisasi : stres atau bahaya terkait dengan masalah tempat kerja yang menyebabkan efek jangka panjang atau pendek, beban kerja yang berat dan kekerasan ditempat kerja.</p> <p><i>Organizational hazards : stressors or hazards associated with workplace issues that cause long or short term effects heavy workloads, stressful interactions and workplaces violence.</i></p>

No	Urutan Dasar Langkah Tugas / Job Steps (* Maksimum 15 Langkah / Maximum 15 Steps)	Bahaya Yang Terkait / Potential Hazard(s)	Tindakan Perbaikan / Recommended Action
1.	Walk around inspection	1.1 Terpeleset lantai licin	1.1.1 berhati-hati saat melangkah. 1.1.2 Gunakan safety shoes.
2.	prepare tools & Area	2.1 Terjepit toolbox 2.2 Tersandung meja	2.1.1 Menghindari titik jepit. 2.1.2 pakai safety shoes & gloves. 2.2.1 tetap berhati-hati 2.2.2 memakai safety shoes.
3.	Doing	3.1 Tangan tergores komponen 3.2 Jari terjepit komponen 3.3 Kaki tertimpa tools	3.1.1 Hindari area gores. 3.1.2 Tidak bergurau saat bekerja. 3.1.3 Gunakan safety gloves 3.2.1 Hindari titik jepit. 3.2.2 memakai safety gloves 3.3.1 pegang tools dengan benar 3.3.2 Fokus saat bekerja 3.3.3 pakai safety shoes.
4.	Doing measure the component	4.1 Tangan tergores vernier 4.2 Tertimpa shaft saat measure	4.1.1 Hindari area tajam 4.1.2 Tetap berhati-hati 4.2.1 Fokus dan berhati-hati. 4.2.2 letakkan pada tempat yang aman.

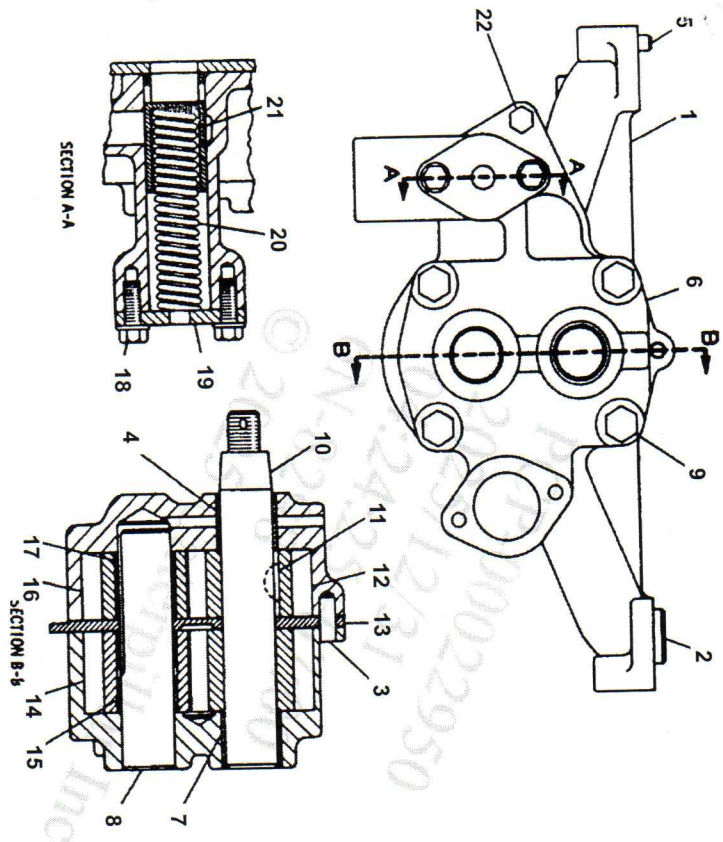

31/12/25, 11:24
6N8298 OIL PUMP GROUP
 Serial No. 43N1173-Up and Engine Serial No. 52K1-Up
 Part of 1M7037 Oil Pump Group shown on Page 49B

Image #	Callout #	Part Number	Part Name	Quantity	Image #	Callout #	Part Number	Part Name	Quantity	
Group Part										
		6N-8298	Oil Pump Group							
Part List Items										
1	1	6N-8299	Body Assem.	1	12	6N-4312	Gear	1		
(Includes)										
1	2	2M-4072	Dowel	1	(scavenge pump drive - 9 teeth)					
1	3	5B-5821	Dowel	1	13	6N-4303	Spacer	1		
1	4 RRP	2H-2356	Bearing	1	1	14	6N-4308	Gear Assem.	1	
1	5	5B-5812	Dowel	1	(oil pump idler - 9 teeth)					
1	6	6N-8311	Body Assem.	1	(Includes)					
(Includes)					15	RRP	3H-2512	Bearing	2	
1	7 RRP	1H-0030	Bearing	1	16		6N-4301	Gear Assem.	1	
1	8	2M-1433	Shaft	1	(scavenge pump idler - 9 teeth)					
1	9	1D-4566	Bolt	4	(Includes)					
1	10	6N-8309	Shaft Assem.	1	17	RRP	4M-9920	Bearing	1	
(oil pump drive - 9 teeth)					1	18		0L-1351	Bolt	2
1	11 RRP	1B-8709	Key	1			5M-2894	Washer	2	
					1	19		8M-5434	Flange Assem.	1
					1	20	RRP	2S-2760	Spring	1
					1	21		2S-2781	Plunger	1
					1	22		0T-0573	Bolt	1



