

Demonstrate Selecting, Using and Maintaining Various Special Tools Correctly

Skill Number CO-OP15GN104

Full Name: Sulton Akbar Alarisda

No ID: 20

Validation Date: 14/3/2026

School: SMK 1 Singosari

PERFORMANCE TASK:

Given some special tools, the student is requested to perform the following tasks:

- Selecting, using, maintaining various Special Tools in the installation of Engine or other system components.
- Perform close the job by ensuring all systems or conditions is in the standard condition.

Safety and Contamination Control must be applied to this process. All literatures will be available.

Preparation	Completed			Hints
	Yes	No	N/A	
The student must complete the knowledge assessment. Minimum passing grade 80%.	<input checked="" type="checkbox"/>	<input type="checkbox"/>	<input type="checkbox"/>	Score special tools Course or subject.

Preparation	Completed			Hints
	Yes	No	N/A	
Prepare related literature	<input checked="" type="checkbox"/>	<input type="checkbox"/>	<input type="checkbox"/>	
Prepare required equipment	<input checked="" type="checkbox"/>	<input type="checkbox"/>	<input type="checkbox"/>	
Prepare related tools	<input checked="" type="checkbox"/>	<input type="checkbox"/>	<input type="checkbox"/>	
Prepare Safety & Contamination Control equipment	<input checked="" type="checkbox"/>	<input type="checkbox"/>	<input type="checkbox"/>	

Tasks	Completed			Observation/Hints
	Yes	No	N/A	
Perform etiquette/manner when starting the job	<input checked="" type="checkbox"/>	<input type="checkbox"/>	<input type="checkbox"/>	
Meet the customer / assessor	<input checked="" type="checkbox"/>	<input type="checkbox"/>	<input type="checkbox"/>	
Perform etiquette/manner when opening the interaction.	<input checked="" type="checkbox"/>	<input type="checkbox"/>	<input type="checkbox"/>	• Perform smile & greetings. • Introduce Student's identity
Explain the purpose of Student's activity.	<input checked="" type="checkbox"/>	<input type="checkbox"/>	<input type="checkbox"/>	
Ask permission to perform the job.	<input checked="" type="checkbox"/>	<input type="checkbox"/>	<input type="checkbox"/>	

Tasks	Completed			Observation/Hints
	Yes	No	N/A	
Selecting, Using and Maintaining Various Special Tools				
1. Inspect the Special Tool before using	<input checked="" type="checkbox"/>	<input type="checkbox"/>	<input type="checkbox"/>	Visual inspection of the Special Tool for wear, cracks, damage
2. Calibrate the special tool before using	<input checked="" type="checkbox"/>	<input type="checkbox"/>	<input type="checkbox"/>	• Torque wrench
3. Remove and install or disassemble and assemble conducted according to correct procedures	<input checked="" type="checkbox"/>	<input type="checkbox"/>	<input type="checkbox"/>	Equipment and tooling are identified and checked for safe and effective operation and must refer to Service manual or SIS procedures
4. Tasks completed without damage to equipment and tools	<input checked="" type="checkbox"/>	<input type="checkbox"/>	<input type="checkbox"/>	Component and tooling are cleaned and stored on the right place
5. Equipment and tooling is cleaned and returned to its correct location	<input checked="" type="checkbox"/>	<input type="checkbox"/>	<input type="checkbox"/>	Cleaned and stored equipment tools on the right place.
6. Work area left clean and tidy	<input checked="" type="checkbox"/>	<input type="checkbox"/>	<input type="checkbox"/>	Area cleaned from spills and wastes.
Documentation:				
Take picture if needed	<input checked="" type="checkbox"/>	<input type="checkbox"/>	<input type="checkbox"/>	

Tasks	Completed			Observation/Hints
	Yes	No	N/A	
Perform close the job by ensuring all systems or conditions is in the standard condition	<input checked="" type="checkbox"/>	<input type="checkbox"/>	<input type="checkbox"/>	• Find the improper condition. • Communicate the finding to the customer/assessor.
Ensure all systems or conditions are in standard condition.	<input checked="" type="checkbox"/>	<input type="checkbox"/>	<input type="checkbox"/>	

Tasks	Completed		Observation/Hints
	Yes	No	
Reporting All relevant documentation completed correctly and approved by customer (if required).	✓		<ul style="list-style-type: none"> • Completing the Task List • Completing Measurement Form/Related Check Sheet, if required • Create Service Report (SIMS), if required • Create SPR, if required • Documenting the failed or damaged parts, if required • Provide Technical Analysis Report/Failure Analysis Report, if required.

Tasks	Completed		Observation/Hints
	Yes	No	
Safety Using APD related to the job	✓		
Follows relevant workplace safety guidelines (tag out, safety equipment)	✓		<ul style="list-style-type: none"> • Comply with safety regulation that applied on the workplace
State and follow safety precautions	✓		<ul style="list-style-type: none"> • Create Job Safety Analysis • Student must follow safety procedure refer to service manual or SIS related to job
Service man completes job without accident due to incorrect procedure using hand tools.	✓		<ul style="list-style-type: none"> • Correct working position. • Correct hand tool related to the job
Tasks completed without damage equipment and tools	✓		

Tasks	Completed		Observation/Hints
	Yes	No	
Environmental Practices & Housekeeping Perform etiquette/manner after completing the job	✓		<ol style="list-style-type: none"> 1. Waste is minimized, waste material, including sludge, solids and other wastes are sorted and stored in bins for recycling or disposal 2. Packaging of goods received is sorted and reused or disposed of by recycling 3. Materials that can be reused are cleaned and stored 4. Waste and scrap are removed following workplace procedures 5. All fluids are disposed of in accordance with enterprise policies and procedures

Tasks	Completed		Observation/Hints
	Yes	No	
Perform etiquette/manner when closing the communication.	✓		<ul style="list-style-type: none"> • Perform smile & greetings. • Ask permission to leave or end the interaction.

General Comments

RESULT:

COMPETENT

NOT YET COMPETENT

(please check (N))

Student:

Sulvan Adam Alfarisa

Name

Date

14-3-2021

Signature



Assessor:

Sulvan TB

Name

Date

14/3/2021

Signature

Supervisor:

Name

Date

Signature

Data Recorded:

Name

Date

Signature

Demonstrate Selecting, Using and Maintaining Various Special Tools Correctly

Skill Number CO-OP15GN104

Full Name: Sulton adon alFarsi

No ID: 20

Validation Date: 14-3-2024

School: SMVA 1 Strydom

PERFORMANCE TASK:

Given some special tools, the student is requested to perform the following tasks:

- Selecting, using, maintaining various Special Tools in the installation of Engine or other system components.
 - Perform dose the job by ensuring all systems or conditions is in the standard condition.
- Safety and Contamination Control must be applied to this process. All literatures will be available.

Prerequisite	Yes	No	N/A	Hints
The student must complete the knowledge assessment. Minimum passing grade 80%.	✓			

Tasks	Completed	Not Completed	Observation / Hints
Prepare related literature	✓		
Prepare required equipment	✓		
Prepare related tools	✓		
Prepare Safety & Contamination Control equipment	✓		

Tasks	Completed	Not Completed	Observation / Hints
Perform etiquette/manner when starting the job	✓		
Meet the customer / assessor	✓		
Perform etiquette/manner when opening the interaction.	✓		
Explain the purpose of Student's activity.	✓		
Ask permission to perform the job.	✓		

Tasks	Completed	Not Completed	Observation / Hints
Selecting, Using and Maintaining Various Special Tools			
1. Inspect the Special Tool before using	✓		
2. Calibrate the special tool before using	✓		
3. Remove and install or disassemble and assemble conducted according to correct procedures	✓		
4. Tasks completed without damage to equipment and tools	✓		
5. Equipment and tooling is cleaned and returned to its correct location	✓		
6. Work area left clean and tidy	✓		
Documentation:			
Take picture if needed	✓		

Tasks	Completed	Not Completed	Observation / Hints
Perform dose the job by ensuring all systems or conditions is in the standard condition	✓		
Ensure all systems or conditions are in standard condition.	✓		

TRAKINDOC0-0P

CO-OP15GN104 - Candidate Performance Guide

Reporting	Competing			Observation/Hints
	Yes	No	N/A	
All relevant documentation completed correctly and approved by customer (if required).	✓			

Task	Compete		Observation/Hints
	Yes	No	
Safety	✓		
Using APD related to the job	✓		
Follows relevant workplace safety guidelines (tag out, safety equipment)	✓		
State and follow safety precautions	✓		
Service man completes job without accident due to incorrect procedure using hand tools.	✓		
Tasks completed without damage equipment and tools	✓		

Tasks	Compete		Observation/Hints
	Yes	No	
Contamination Control	✓		
Environmental Practices & Housekeeping	✓		

Tasks	Compete		Observation/Hints
	Yes	No	
Perform safe/quiet/manner after completing the job	✓		
Perform etiquette/manner when closing the communication.	✓		

TRAKINDOC0-0P

CO-OP15GN104 - Candidate Performance Guide

General Comments

RESULT: **COMPETENT** NOT YET COMPETENT (Please check (✓))

Student: **Sulpan Adam Alfariski** Date: **19-8-2016**

Assessor: **Sulpan** Date: **19/3/2016**

Supervisor: _____ Date: _____ Signature: _____

Data Recorded: _____ Name: _____ Date: _____ Signature: _____

2. Install the oil drain plug(s). Tighten the plug(s) to 70 ± 14 N·m (50 ± 10 lb ft). If equipped with a drain line valve, turn the valve knob clockwise (CW) to shut the drain.

Change Filter(s)

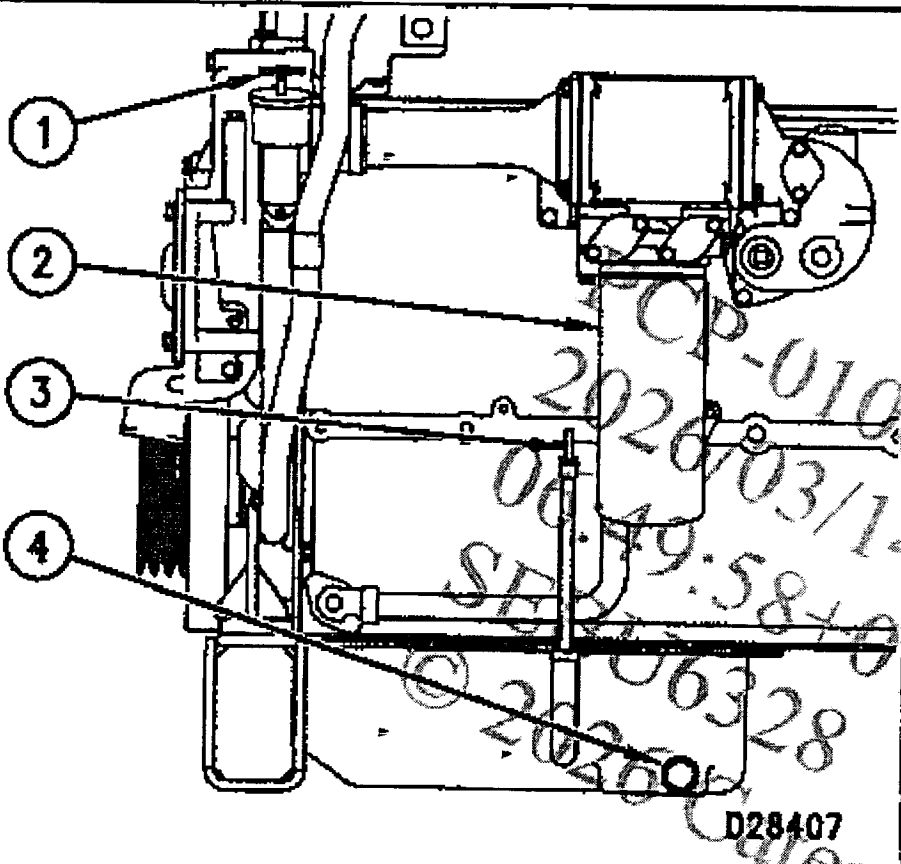

Oil Filler Cap (1), Oil Filter (2), Oil Level Gauge (dipstick) (3), and Oil Drain Plug (4).

1. Use a 2P8250 Filter Wrench to remove the oil filter (2) and optional bypass oil filter, if equipped.

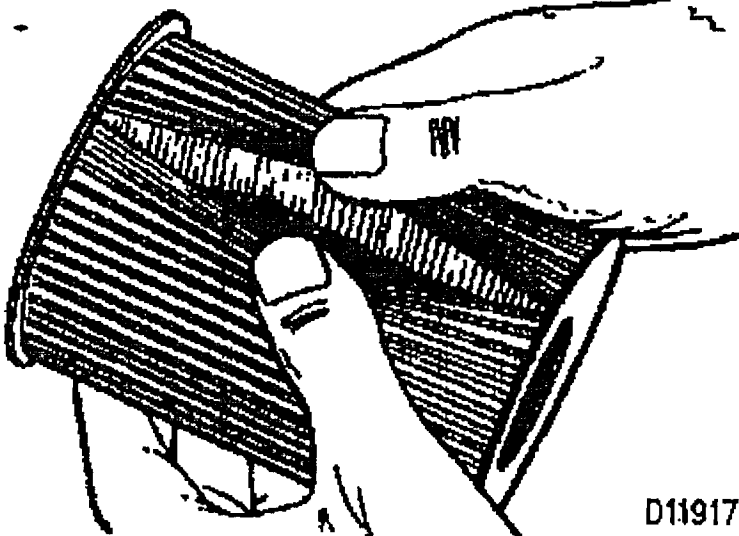

Element with debris.

2. Use a 4C5084 Oil Filter Cutter (which replaced the former 6V7905 Service Tool) to cut the oil filter open. Spread the pleats apart and inspect the element for metal debris. An excessive

amount of debris in the oil filter element may be indicative of early wear or a pending failure.

Use a magnet to differentiate between the ferrous and non-ferrous metals found in your oil filter element. Ferrous metals may indicate wear on the steel and cast iron parts of your engine.

Non-ferrous metals may indicate wear on the aluminum, brass or bronze parts of your engine, such as main and rod bearings, turbocharger bearings and cylinder head wear.

Due to normal wear and friction, it is not uncommon to find small amounts of debris in the oil filter element. Consult your Caterpillar dealer to arrange for further analysis if an excessive amount of debris is found in your oil filter element.



3. Wipe the sealing surface of the filter mounting base. Make sure all of the old gasket is removed.

NOTE: Change oil filter(s) at every oil change. Make sure to use the correct Caterpillar oil filter(s) for your engine arrangement.

NOTICE

Caterpillar oil filters are built to Caterpillar specifications. Use of an oil filter not recommended by Caterpillar could result in severe engine damage to your engine bearings, crankshaft, etc., as a result of the larger debris particles from unfiltered oil entering your engine lubricating system. Only use oil filters recommended by Caterpillar.



4. Apply a small amount of clean engine oil to the new filter gasket.

NOTICE

Do NOT fill the oil filters with oil before installing them. This oil would not be filtered and could be contaminated. Contaminated oil will cause accelerated wear to engine components.

5. Install the new filter(s) until the gasket contacts the base. Tighten the filter 3/4 of a turn more by hand. Do not over tighten.

* Replace the bypass filter (if equipped) as instructed in Steps 3, 4 and 5. The Caterpillar bypass filter will require an additional 2.5 L (2.6 U.S. qts) of oil.

Fill Crankcase

6. Remove the oil filler cap (1). Refer to Lubricant Specifications, Lubricant Viscosities and Refill Capacities chart for the proper oil and quantity to use for this engine. Fill the crankcase with the proper amount of oil. Under Filling or overfilling of engine crankcase oil can cause engine damage. Before starting the engine, ensure your oil level is within the correct operating range on the ENGINE STOPPED side of the dipstick (3).

NOTICE

If equipped with an auxiliary oil filter or system, extra oil must be added when filling the crankcase. Follow the OEM or filter manufacturer's recommendations. If the extra oil is not added, the engine may starve for oil.

To prevent crankshaft or bearing damage, crank engine to fill all filters BEFORE starting. Do Not crank engine for more than 30 seconds.

7. Start and run the engine at LOW IDLE for two minutes to ensure the lube system (including auxiliary filters, etc.) has oil and the oil filter(s) are filled. Inspect for oil leaks.
8. Stop the engine and allow the oil to drain back to the sump for a minimum of ten minutes.
9. Remove the dipstick to check the oil level. Maintain the oil level to the FULL mark in the FULL RANGE zone on the ENGINE STOPPED side of the dipstick.

Crankcase Breather

If the crankcase breather is not maintained on a regular basis, it will become plugged. A plugged crankcase breather would result in excessive crankcase pressure that may cause crankshaft seal leakage.

Clean

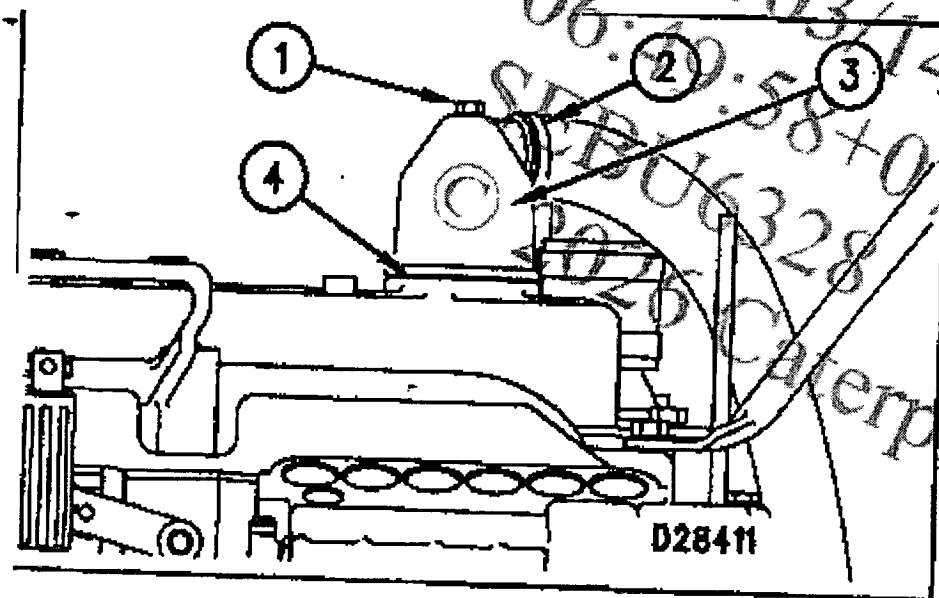

1. Loosen breather retaining bolt (1).
2. Loosen hose clamp(s) (2) and remove breather assembly (3) and seal (4).
3. Wash the breather in clean, nonflammable solvent. Allow the breather assembly to dry.
4. Install a new seal.
5. Assemble the breather. Install the breather in reverse order of removal.
6. Tighten the hose clamp(s) (2).